

CR, CRI, CRN

Vertical multistage centrifugal pumps
60 Hz



be
think
innovate

GRUNDFOS 

1. Product introduction	3	10. Technical data	37
Features and benefits	3	CR 1s	37
Terminal box positions	4	CRI 1s	38
Viscosity	4	CRN 1s	39
Ambient temperature and altitude	4	CR 1	40
		CRI 1	41
2. Applications	5	CRN 1	42
		CR 3	43
3. Performance range	6	CRI 3	44
		CRN 3	45
4. Product range	7	CR 5	46
		CRI 5	47
5. Identification	9	CRN 5	48
Type key	9	CR 10	49
		CRI 10	50
6. Construction	10	CRN 10	51
CR 1s, 1, 3, 5, 10, 15 and 20	10	CR 15	52
CRI, CRN 1s, 1, 3, 5, 10, 15 and 20	10	CRI 15	53
CR 32, 45, 64 and 90	11	CRN 15	54
CRN 32, 45, 64 and 90	11	CR 20	55
CR 120 and 150	12	CRI 20	56
CRN 120 and 150	12	CRN 20	57
		CR 32	58
7. Operating conditions	13	CRN 32	59
Pumped liquids	13	CR 45	60
Working and inlet pressure	16	CRN 45	61
Operating range of the shaft seal	17	CR 64	62
Maximum inlet pressure	18	CRN 64	63
		CR 90	64
8. Selection and sizing	19	CRN 90	65
Selection of pumps	19	CR 120	66
How to read the curve charts	23	CRN 120	67
Guidelines to performance curves	23	CR 150	68
		CRN 150	69
9. Performance curves	24	11. Motor data	70
CR, CRI, CRN 1s	24		
CR, CRI, CRN 1	25	12. Accessories	72
CR, CRI, CRN 3	26	Pipework connections	72
CR, CRI, CRN 5	27	CR flange guide	76
CR, CRI, CRN 10	28		
CR, CRI, CRN 15	29	13. Variants	77
CR, CRI, CRN 20	30	Lists of variants - on request	77
CR, CRN 32	31	Motors	77
CR, CRN 45	32	Connections and other variants	77
CR, CRN 64	33	Shaft seals	77
CR, CRN 90	34	Pumps	77
CR, CRN 120	35		
CR, CRN 150	36	14. Submittal data	81
		15. Quotation text	83
		16. Grundfos Product Center	85
		Grundfos GO	86

1. Product introduction

This data booklet deals with Grundfos CR, CRI and CRN pumps.



Fig. 1 CR, CRI and CRN pumps

TM02 7698 3803

Features and benefits

Grundfos CR, CRI, CRN pumps are vertical multistage centrifugal pumps. The in-line design enables the pump to be installed in a horizontal one-pipe system where the suction and discharge ports are in the same horizontal plane and have the same pipe dimensions. This design provides a more compact pump design and pipework.

Grundfos CR pumps come with various pump sizes and various numbers of stages to provide the flow and the pressure required.

CR pumps are suitable for a variety of applications from pumping of potable water to pumping of chemicals. The pumps are therefore used in a wide variety of pumping systems where the performance and material of the pump meet specific demands.

The CR pumps consist of two main components: the motor and the pump unit. The motor on a CR pump is a heavy-duty Grundfos specified motor.

The pump unit consists of optimized hydraulics, various types of connections, an outer sleeve, a top and various other parts.

CR pumps are available in various material versions according to the pumped liquid.

Pump

The CR pump is a non-self-priming, vertical multistage centrifugal pump. The pumps are available with a Grundfos standard motor.

The pump consists of a base and a pump head. The chamber stack and the outer sleeve are secured between the pump head and the base by means of staybolts. The base has suction and discharge ports on the same level (in-line).

All pumps are equipped with a maintenance-free mechanical shaft seal of the cartridge type.

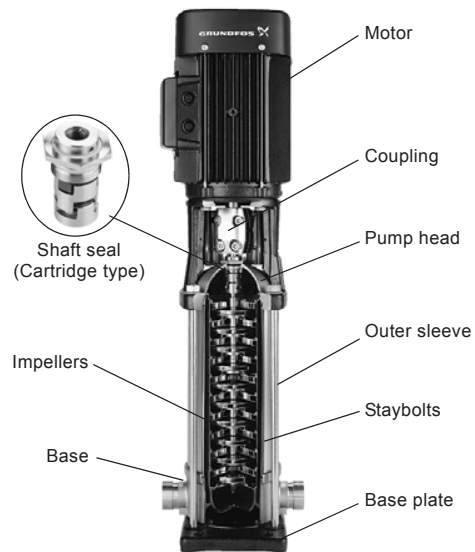

Fig. 2 CR pump

CR pump with ANSI/NSF 61 listing is available. See UL file MH26400 or contact Grundfos.



Motor

Grundfos standard motors - ML and Baldor® motors

CR, CRI and CRN pumps are fitted with a Grundfos specified motor. The motors are all heavy-duty 2-pole, NEMA C-face motors.

GR5357 - GR3395

Electrical data

Mounting designation	NEMA
Insulation class	F & B
Efficiency class*	Energy efficient Premium efficiency - on request for 15 Hp and above
Enclosure class	TEFC - Totally Enclosed Fan Cooled (Grundfos standard) ODP - Open Drip Proof - on request
60 Hz standard voltages	1 x 115/208-230 V 3 x 208-230/460 V 3 x 575 V
The motors are rated for:	
	Baldor ML
Approvals	  

* 1-10 Hp ML motors are premium efficiency as standard.

Optional motors

The Grundfos standard range of motors covers a wide variety of application demands. However, for special applications or operating conditions, custom-built motor solutions can be provided.

For special applications or operating conditions, Grundfos offers custom-built motors such as:

- explosion proof motors
- motors with anti-condensation heating unit
- low-noise motors
- premium efficiency motors
- motors with thermal protection.

Motor protection

Single-phase Grundfos specified motors up to 7.5 Hp have a built-in thermal overload switch.

Three-phase motors **must** be connected to a motor starter in accordance with local regulations.

Terminal box positions

As standard the terminal box is mounted on the suction side of the pump.

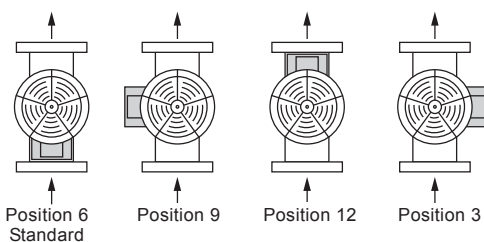

Fig. 3 Terminal box positions

TM02 18 05 2001

Viscosity

The pumping of liquids with densities or kinematic viscosities higher than those of water will cause a considerable pressure drop, a drop in the hydraulic performance and a rise in the power consumption. In such situations, the pump should be fitted with a larger motor. If in doubt, contact Grundfos.

Ambient temperature and altitude

If the ambient temperature exceeds the maximum temperature limits of the pump or the pump is installed at an altitude exceeding the altitude values in the chart below, the motor must not be fully loaded due to the risk of overheating.

Overheating may result from excessive ambient temperatures or the low density and consequently low cooling effect of the air at high altitudes. In such cases, it may be necessary to use a motor with a higher rated output (P_2).

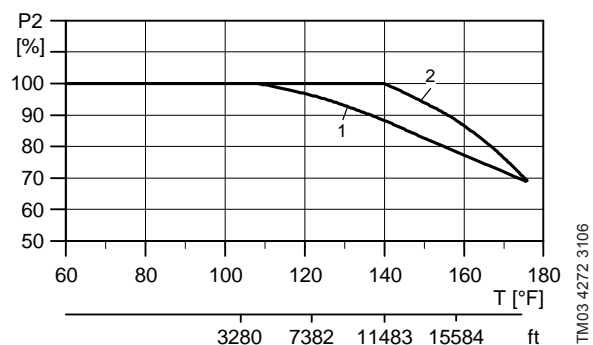

Fig. 4 Relationship between motor output (P_2) and ambient temperature/altitude

TM03 4272 3106

Legend

Pos.	Description
1	NEMA energy efficient motors
2	NEMA premium-efficiency motors

Example: From fig. 4 it appears that P_2 must be reduced to 88 % when a pump with a NEMA premium-efficiency ML motor is installed 15,584 ft (4750 m) above sea level. At an ambient temperature of 167 °F (75 °C), P_2 of a standard-efficiency motor must be reduced to 74 % of rated output.

In cases where both the maximum temperature and the maximum altitude are exceeded, the derating factors must be multiplied. Example: $0.89 \times 0.89 = 0.79$.

2. Applications

Application	CR, CRI	CRN
Water supply		
Filtration and transfer at waterworks	●	○
Distribution from waterworks	●	○
Pressure boosting in mains	●	○
Pressure boosting in high-rise buildings, hotels, etc.	●	○
Pressure boosting for industrial water supply	●	○
Industry		
Pressure boosting in...		
process water systems	●	●
washing and cleaning systems	●	●
vehicle washing tunnels	●	○
fire fighting systems	●	
Liquid transfer in...		
cooling and air-conditioning systems (refrigerants)	●	○
boiler feed and condensate systems	●	○
machine tools (cooling lubricants)	●	●
aquafarming ★	●	○
Transfer of...		
oils and alcohols	●	●
acids and alkalis ★		●
glycol and coolants	●	
Water treatment		
Ultra-filtration systems		●
Reverse osmosis systems ★		●
Softening, ion exchange, demineralizing systems		●
Distillation systems		●
Separators	●	●
Swimming pools ★		●
Irrigation		
Field irrigation (flooding)	●	○
Sprinkler irrigation	●	○
Drip-feed irrigation	●	○

- Recommended version.
- Alternative version.

★ CRT, CRTE version available. For further information about CRT, CRTE pumps, see [Pumped liquids](#) on page 13 or related CRT, CRTE product guide.

3. Performance range

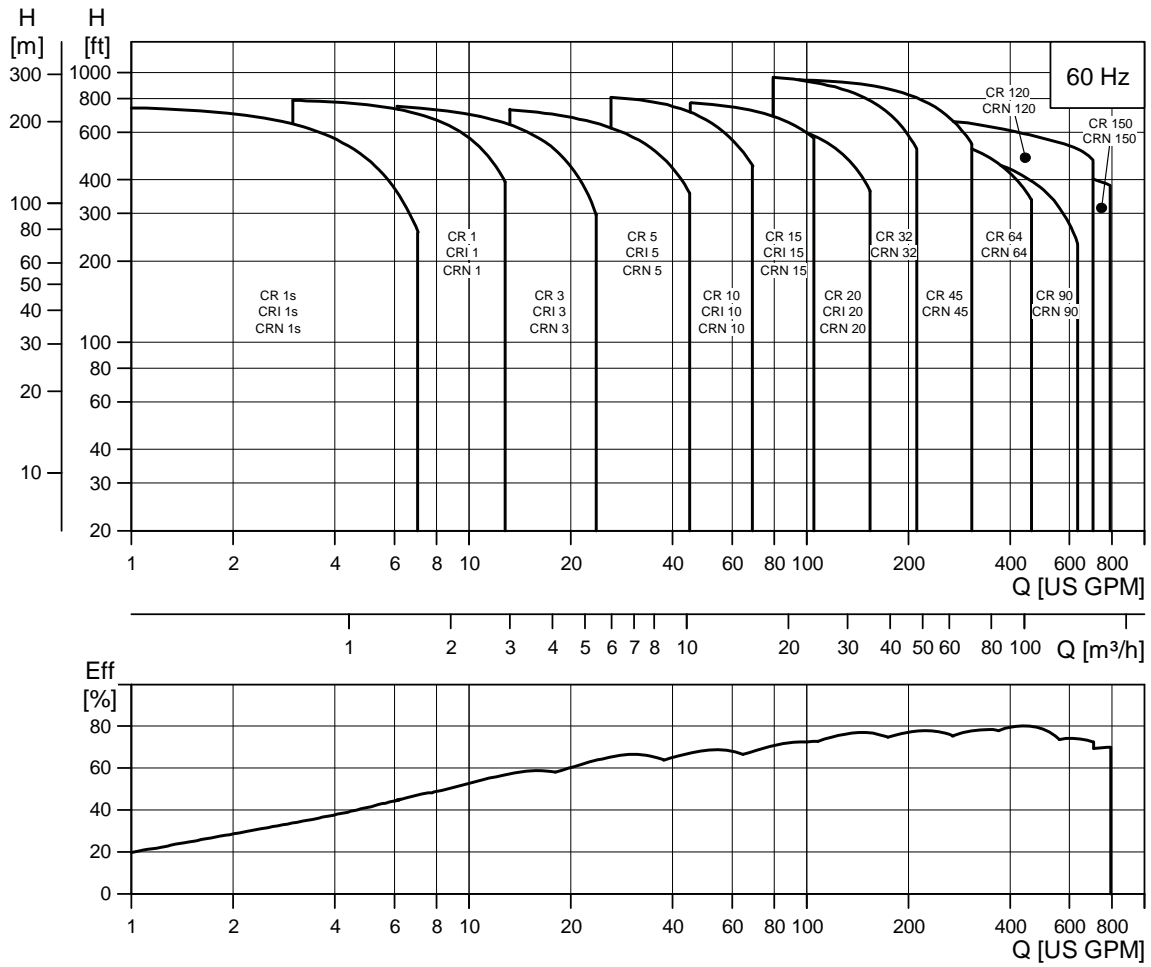

TM02 5518 0209

4. Product range

Range	CR 1s	CR 1	CR 3	CR 5	CR 10	CR 15	CR 20
Nominal flow rate [US gpm]	4.5	8.5	15	30	55	95	110
Temperature range [°F]	-4 to +250						
Temperature range [°F] - on request	-40 to +356						
Max. working pressure [psi]★	362	362	362	362	362	362	362
Max. working pressure [psi] - on request	-	725	725	725	725	725	725
Max. pump efficiency [%]	35	49	59	67	70	72	72
CR pumps							
CR: Flow range [US gpm]	0.5 - 5.7	1 - 12.8	1.5 - 23.8	3-45	5.5 - 70	9.5 - 125	11-155
CR: Max. pump pressure (H [ft])	760	790	790	780	820	800	700
CR: Motor power [Hp]	.33 - 2	.33 - 3	.33 - 5	.75 - 7.5	.75 - 15	2-25	3-25
Version							
CR: Cast iron and stainless steel AISI 304	•	•	•	•	•	•	•
CRI: Stainless steel AISI 304	•	•	•	•	•	•	•
CRN: Stainless steel AISI 316	•	•	•	•	•	•	•
CRT, CRTE: Titanium	-	See CRT, CRTE product guide					-
CR pipe connection							
Oval flange (NPT)	1"	1"	1"	1.25"	2"	2"	2"
Oval flange (NPT) - on request	1.25"	1.25"	1.25"	1"	1.5"	-	-
ANSI flange size	1.25"	1.25"	1.25"	1.25"	2"	2"	2"
ANSI flange size - on request	-	-	-	-	-	-	-
ANSI flange class	250 lb.	250 lb.	250 lb.	250 lb.	250 lb.	250 lb.	250 lb.
CRI pipe connection							
Oval flange (NPT)	1"	1"	1"	1.25"	2"	2"	2"
Oval flange (NPT) - on request	1.25"	1.25"	1.25"	1"	1.5"	-	-
ANSI flange size	1.25"	1.25"	1.25"	1.25"	2"	2"	2"
ANSI flange class	300 lb.	300 lb.	300 lb.	300 lb.	300 lb.	300 lb.	300 lb.
Clamp coupling (NPT) - on request	1", 1.25"	1", 1.25"	1", 1.25"	1", 1.25"	1.5", 2"	1.5", 2"	1.5", 2"
Union (NPT ext. Thread) - on request	2"	2"	2"	2"	-	-	-
CRN pipe connection							
PJE (Victaulic)	1.25"	1.25"	1.25"	1.25"	2"	2"	2"
PJE (Victaulic) - on request	-	-	-	-	-	-	-
ANSI flange size	1.25"	1.25"	1.25"	1.25"	2"	2"	2"
ANSI flange size - on request	-	-	-	-	-	-	-
ANSI flange class	300 lb.	300 lb.	300 lb.	300 lb.	300 lb.	300 lb.	300 lb.
Clamp coupling (NPT) - on request	1", 1.25"	1", 1.25"	1", 1.25"	1", 1.25"	1.5", 2"	1.5", 2"	1.5", 2"
Union (NPT ext. Thread) - on request	2"	2"	2"	2"	-	-	-
CRT pipe connection							
PJE coupling (Vitaalic)	-	1.25"	1.25"	1.25"	2"	2"	-
ANSI flange size - on request	-	-	-	-	2"	2"	-

• Available.

★ See section 7. *Operating conditions* on page 13 for specific working pressures.

Range	CR 32	CR 45	CR 64	CR 90	CR 120	CR 150
Nominal flow rate [US gpm]	140	220	340	440	610	750
Temperature range [°F]	-22 to +250 ¹⁾				-22 to +250 ¹⁾ & 2)	
Temperature range [°F] - on request	-40 to +356				-	-
Max. working pressure [psi]★	435	435	435	435	435	435
Max. working pressure [psi] - on request	580	580	580	580	-	-
Max. pump efficiency [%]	76	78	79	80	75	73
CR pumps						
CR: Flow range [US gpm]	14-210	22-310	34-450	44-630	61-700	75-790
CR: Max. pump pressure (H [ft])	995	940	565	595	685	570
CR: Motor power [Hp]	5-50	7.5-60	10-60	15-60	20-100	25-100
Version						
CR:						
Cast iron and stainless steel AISI 304	•	•	•	•	•	•
CRI:						
Stainless steel AISI 304	-	-	-	-	-	-
CRN:						
Stainless steel AISI 316	•	•	•	•	•	•
CRT, CRTE:						
Titanium	-	-	-	-	-	-
CR pipe connection						
Oval flange (NPT)	-	-	-	-	-	-
Oval flange (NPT) - on request	-	-	-	-	-	-
ANSI flange size	2.5"	3"	4"	4"	5" ³⁾	5" ³⁾
ANSI flange size - on request	3"	4"	5" ³⁾	5" ³⁾	6"	6"
ANSI flange class	125/ 250 lb.	125/ 250 lb.	125/ 250 lb.	125/ 250 lb.	125/ 250 lb.	125/ 250 lb.
CRI pipe connection						
Oval flange (NPT)	-	-	-	-	-	-
Oval flange (NPT) - on request	-	-	-	-	-	-
ANSI flange size	-	-	-	-	-	-
ANSI flange class	-	-	-	-	-	-
Clamp coupling (NPT) - on request	-	-	-	-	-	-
Union (NPT ext. Thread) - on request	-	-	-	-	-	-
CRN pipe connection						
PJE (Vitaallic)	-	-	-	-	-	-
PJE (Vitaallic) - on request	3"	4"	4"	4"	4"	4"
ANSI flange size	2.5"	3"	4"	4"	5"	5"
ANSI flange size - on request	3"	-	-	5"	6"	6"
ANSI flange class	150/ 300 lb.	150/ 300 lb.	150/ 300 lb.	150/ 300 lb.	150/ 300 lb.	150/ 300 lb.
Clamp coupling (NPT) - on request	-	-	-	-	-	-
Union (NPT ext. Thread) - on request	-	-	-	-	-	-
CRT pipe connection						
PJE coupling (Vitaallic)	-	-	-	-	-	-
ANSI flange size - on request	-	-	-	-	-	-

• Available.

★ See section 7. *Operating conditions* on page 13 for specific working pressures.

1) CRN 32 to CRN 90 with HQQE shaft seal: -40 °F to +250 °F.

2) CR, CRN 120 and 150 with 75 or 100 Hp motors with HBQE shaft seal: 0 °F to +250 °F.

3) CR 5" flange is not manufactured to ANSI specification. Gasket contact surface is approximately 0.25". CR 6" ANSI flange adapter is manufactured to ANSI B16.5 specification.

5. Identification

Type key

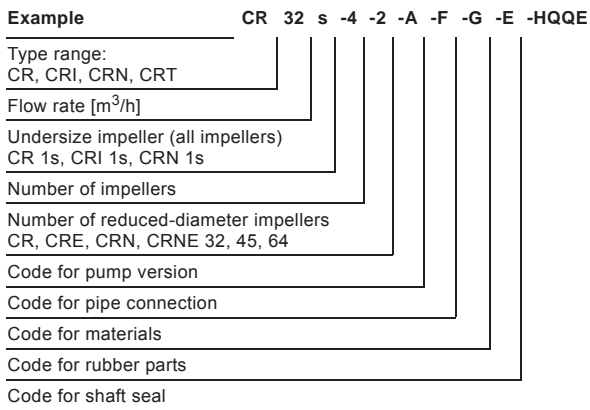

Key to codes

Code	Description
Pump version	
A	Basic version
B	Oversize motor
C	CR compact
D	Pump with pressure intensifier*
E	Pump with certificate
F	Pump for high temperatures (with air-cooled top)
G	E-pump without control panel
H	Horizontal version
I	Different pressure rating
J	E-pump with a different maximum speed
K	Pump with low NPSH
L	Pump including Grundfos CUE and certificate
M	Magnetic drive
N	With sensor
O	Cleaned and dried
P	Undersize motor
Q	High-pressure pump with high-speed MGE motor*
R	Belt driven pump
S	High-pressure pump
T	Thrust handling device*
U	ATEX approved pump
V	Cascade function
W	Deep-well pump with ejector*
X	Special version
Y	Electropolished
Z	Pumps with bearing flange
Pipe connection	
A	Oval flange
B	NPT thread
CA	FlexiClamp
CX	Triclamp*
F	DIN flange
FC	DIN 11853-2 flange (collar flange)
FE	EN 1092-1, type E
G	ANSI flange
J	JIS flange
N	Changed diameter of ports
P	PJE coupling (Victaulic type)
X	Special version

Code	Description
Materials	
A	Basic version
B	Tungsten carbide / Tungsten carbide
C	Carbon free pump
D	Carbon-graphite filled PTFE (bearings)/Tungsten carbide
E	Pickled and passivated (Only Japan)
H	Flanges and base plate EN 1.4408
K	Bronze (bearings)/Tungsten carbide
L	Motor stool, base plate and flanges EN 1.4408
M	Motor stool, base plate, coupling and flanges EN 1.4408 and coupling guards in cobber. Bolts, nuts and spacing pipes EN 1.4401 or higher grade
N	Flanges EN 1.4408
P	PEEK neck ring
Q	Silicon carbide/Silicon carbide bearing in pump and Silicon carbide/Silicon carbide seal faces in thrust handling device
R	Silicon carbide/Silicon carbide bearing
S	PTFE neck rings
T	Base plate EN 1.4408
U	Silicon carbide/Silicon carbide bearing in pump and Silicon carbide/Tungsten carbide seal faces in thrust handling device
X	Special version
Code for rubber parts in pump	
E	EPDM
F	FXM (Fluoraz®)
K	FFKM (Kalrez®)
N	Neoprene
V	FKM (Viton®)
Shaft seal type designation	
A	O-ring seal with fixed driver*
H	Balanced cartridge seal with O-ring
O	Double seal, back-to-back*
P	Double seal, tandem*
X	Special version*
Seal face material	
B	Carbon, synthetic resin-impregnated
U	Cemented tungsten carbide
Q	Silicon carbide
X	Other ceramics*
Secondary seal material (rubber parts)	
E	EPDM
F	FXM (Fluoraz®)
K	FFKM (Kalrez®)
V	FKM (Viton®)

* Option. See the CR "Custom-built pumps" data booklet available on Grundfos Product Center. See QR code or link below.



<http://net.grundfos.com/qr/i/96486346>

Shaft seal

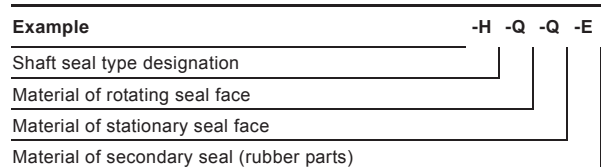

6. Construction

CR 1s, 1, 3, 5, 10, 15 and 20



TM02 1198 0601 - GR7377 - GR7379

Sectional drawing

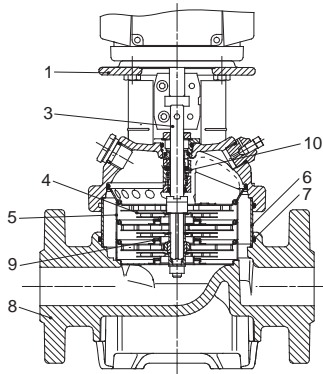

TM02 1194 1403

Materials: CR

Pos.	Designation	Materials	AISI/ASTM
1	Pump head	Cast iron	A 48-30 B
3	Shaft	Stainless steel	AISI 316 ¹⁾ AISI 431 ²⁾
4	Impeller	Stainless steel	AISI 304
5	Chamber	Stainless steel	AISI 304
6	Outer sleeve	Stainless steel	AISI 304
7	O-ring for outer sleeve	EPDM or FKM	
8	Base	Cast iron	A 48-30 B
9	Neck ring	PTFE	
10	Shaft seal	Cartridge type	
	Bearing rings	Silicon carbide	
	Rubber parts	EPDM or FKM	
12	FGJ flange	Cast iron	A 48-30 B

1) CR 1s, 1, 3, 5

2) CR 10, 15, 20

3) Stainless steel available on request.

4) CF 8M is cast equivalent of AISI 316 stainless steel.

5) CRI/CRN 1s, 1, 3, 5

6) CRN 10, 15, 20

7) CRI 10, 15, 20

CRI, CRN 1s, 1, 3, 5, 10, 15 and 20



TM02 1808 2001 - GR7373 - GR7375

Sectional drawing

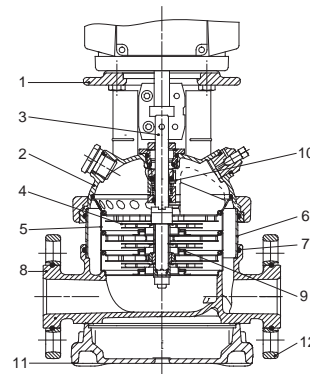

TM03 2166 3805

Materials: CRI, CRN

Pos.	Designation	Materials	AISI/ASTM
1	Pump head	Cast iron ³⁾	A 48-30 B
2	Pump head cover	Stainless steel	CF 8M ⁴⁾
3	Shaft	Stainless steel	AISI 316 ⁵⁾ AISI 329 ⁶⁾ AISI 431 ⁷⁾
8	Base	Stainless steel	CF 8M ⁴⁾
9	Neck ring	PTFE	
10	Shaft seal	Cartridge type	
11	Base plate	Cast iron ³⁾	A 48-30 B
	Bearing rings	Silicon carbide	
	Rubber parts	EPDM or FKM	
CRI			
4	Impeller	Stainless steel	AISI 304
5	Chamber	Stainless steel	AISI 304
6	Outer sleeve	Stainless steel	AISI 304
7	O-ring for outer sleeve	EPDM or FKM	
12	FGJ flange ring	Ductile iron ³⁾	A 65-45-12
	Oval flange	Stainless steel	AISI 316
CRN			
4	Impeller	Stainless steel	AISI 316
5	Chamber	Stainless steel	AISI 316
6	Outer sleeve	Stainless steel	AISI 316
7	O-ring for outer sleeve	EPDM or FKM	
12	FGJ flange ring	Ductile iron ³⁾	A 65-45-12

CR 32, 45, 64 and 90



TM01 2150 1298

Sectional drawing

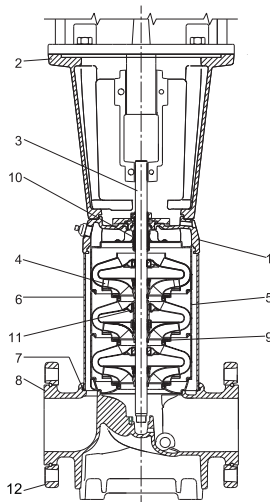

TM06 0691 0714

Materials: CR

Pos.	Designation	Materials	AISI/ASTM
1	Pump head	Cast iron EN-GJS-500-7	ASTM 80-55-06
2	Motor stool	Cast iron EN-GJL-200	ASTM 25B
3	Shaft	Stainless steel	AISI 431
4	Impeller	Stainless steel	AISI 304
5	Chamber	Stainless steel	AISI 304
6	Sleeve	Stainless steel	AISI 304
7	O-ring for sleeve	EPDM or FKM	
8	Base	Cast iron EN-GJS-500-7	ASTM 80-55-06
9	Neck ring	Carbon-graphite-filled PTFE	
10	Shaft seal		
11	Bearing ring	SiC/SiC	
12	Flange ring	Ductile iron	A 65-45-12
	Rubber parts	EPDM or FKM	

CRN 32, 45, 64 and 90



TM02 7399 3403

Sectional drawing

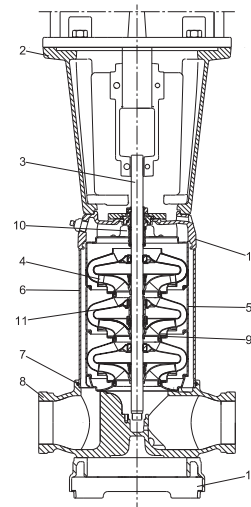

TM01 1837 3713

Materials: CRN

Pos.	Designation	Materials	AISI/ASTM
1	Pump head	Stainless steel	CF 8M equal to AISI 316
2	Motor stool	Cast iron EN-GJL-200 ¹⁾	ASTM 25B
3	Shaft	Stainless steel	
4	Impeller	Stainless steel	AISI 316
5	Chamber	Stainless steel	AISI 316
6	Sleeve	Stainless steel	AISI 316
7	O-ring for sleeve	EPDM or FKM	
8	Base	Stainless steel	CF 8M equal to AISI 316
9	Neck ring	Carbon-graphite-filled PTFE	
10	Shaft seal		
11	Bearing ring	SiC/SiC	
12	Base plate	Cast iron EN-GJS-500-7 ¹⁾	ASTM 88-55-06
	Flange ring	Ductile iron ¹⁾	A 65-45-12
	Rubber parts	EPDM or FKM	

¹⁾ Stainless steel available on request.

CR 120 and 150



GrA3731

Sectional drawing

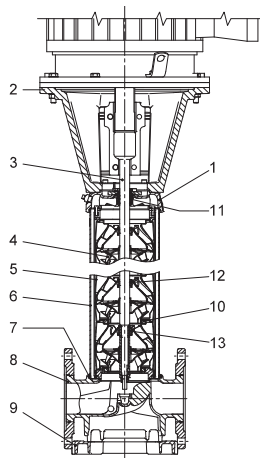

TM03 8835 2607

Materials: CR

Pos.	Designation	Materials	AISI/ASTM
1	Pump head	Ductile iron	A 536 65-45-12
2	Motor stool (15-60 Hp)	Cast iron	A48-30 B
	Motor stool (75-100 Hp)	Ductile iron	A 536 65-45-12
3	Shaft	Stainless steel	AISI 431
4	Impeller	Stainless steel	AISI 304
5	Chamber	Stainless steel	AISI 304
6	Outer sleeve	Stainless steel	AISI 316
7	O-ring for outer sleeve	EPDM or FKM	
8	Base	Ductile iron	A 536 65-45-12
9	Base plate	Ductile iron	A 536 65-45-12
10	Neck ring	PTFE	
11	Shaft seal ¹⁾	Cartridge type	
12	Support bearing	PTFE	
13	Bearing rings	Silicone carbide	
	Rubber parts	EPDM or FKM	

¹⁾ Ø22 mm shaft, 15-60 Hp. Ø32 mm shaft, 75-100 Hp.

CRN 120 and 150



GrA3732 - GrA3735

Sectional drawing

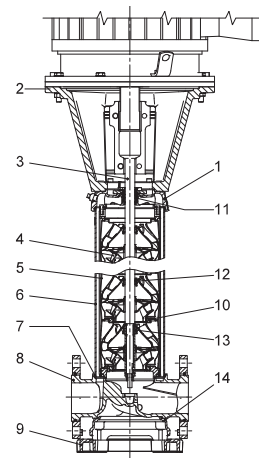

TM03 8836 2607

Materials: CRN

Pos.	Designation	Materials	AISI/ASTM
1	Pump head	Stainless steel	A 351 CF 8M
2	Motor stool (15-60 Hp)	Cast iron	A48-30 B
	Motor stool (75-100 Hp)	Ductile iron	A 536 65-45-12
3	Shaft	Stainless steel	SAF 2205
4	Impeller	Stainless steel	AISI 316
5	Chamber	Stainless steel	AISI 316
6	Outer sleeve	Stainless steel	AISI 316
7	O-ring for outer sleeve	EPDM or FKM	
8	Base	Stainless steel	A 351 CF 8M
9	Base plate	Ductile iron ¹⁾	A 536 65-45-12
10	Neck ring	PTFE	
11	Shaft seal ²⁾	Cartridge type	
12	Support bearing	PTFE	
13	Bearing rings	Silicone carbide	
14	Base plate	Ductile iron ¹⁾	A 536 65-45-12
	Rubber parts	EPDM or FKM	

¹⁾ Stainless steel available on request.

²⁾ Ø22 mm shaft, 15-60 Hp. Ø32 mm shaft, 75-100 Hp.

7. Operating conditions

Pumped liquids

CR, CRI, CRN pumps are designed to pump thin, non-explosive liquids, not containing solid particles or fibers. The liquid must not chemically attack the pump materials. When pumping liquids with a density and/or viscosity higher than that of water, oversized motors must be used, if required.

Whether a pump is suitable for a particular liquid depends on a number of factors of which the most important are the chloride content, pH value, temperature and content of chemicals, oils, etc.

Please note that aggressive liquids (e.g. sea water and some acids) may attack or dissolve the protective oxide film of the stainless steel and thus cause corrosion. The CR, CRI, CRN pump types are suitable for the following liquids:

CR, CRI

- Non-corrosive liquids.

For liquid transfer, circulation and pressure boosting of cold or hot clean water.

CRN

- Industrial liquids.

In systems where all parts in contact with the liquid must be made of high-grade stainless steel.

CRT

- Saline liquids
- hypochlorites
- acids.

For saline or chloride-containing liquids such as sea water or oxidizing agents such as hypochlorites, CRT pumps of titanium are available. See separate product guide on CRT.

List of pumped liquids

A number of typical liquids are listed on the following pages.

Other pump versions may be applicable, but those stated in the list are considered to be the best choices. The table is intended as a general guide only, and cannot replace actual testing of the pumped liquids and pump materials under specific working conditions. The list should, however, be applied with some caution as factors such as the following may affect the chemical resistance of a specific pump version:

- concentration of the pumped liquid
- liquid temperature
- pressure.

Safety precautions must be made when pumping dangerous liquids.

Notes

D	Often with additives.
E	Density and/or viscosity differ from that of water. Allow for this when calculating motor output and pump performance.
F	Pump selection depends on many factors. Contact Grundfos.
H	Risk of crystallization/precipitation in shaft seal
1	The pumped liquid highly inflammable.
2	The pumped liquid is combustible.
3	Insoluble in water.
4	Low self-ignition point.

Pumped liquid	Note	Liquid concentration, liquid temperature	CR		CRN	
			1s, 1, 3, 5, 10, 15, 20	32, 45, 64, 90, 120, 150	1s, 1, 3, 5, 10, 15, 20	32, 45, 64, 90, 120, 150
Acetic acid CH ₃ COOH		5 %, 68 °F			HQQE	HQQE/HBQE
Acetone CH ₃ COCH ₃	1, F	100 %, 68 °F			HBQE	HQQE/HBQE
Alkaline degreasing agent	D, F		HQQE	HQQE/HBQE		
Ammonium bicarbonate NH ₄ HCO ₃	E	20 %, 86 °F			HQQE	HQQE/HBQE
Ammonium hydroxide NH ₄ OH		20 %, 104 °F	HQQE	HQQE/HBQE		
Aviation fuel	1, 3, 4, F	100 %, 68 °F	HQB	HQQV/HBQV		
Benzoic acid C ₆ H ₅ COOH	H	0,5 %, 68 °F			HQQV	HQQV/HBQV
Boiler water		< 248 °F	HQQE	HQQE/HBQE		
	F	248 °F - 356 °F	-	-		
Calcareous water		< 194 °F	HQQE	HQQE		
Calcium acetate (as coolant with inhibitor) Ca(CH ₃ COO) ₂	D, E	30 %, 122 °F	HQQE	HQQE		
Calcium hydroxide Ca(OH) ₂	E	Saturated solution, 122 °F	HQQE	HQQE		
Chloride-containing water	F	< 86 °F, max. 500 ppm			HQQE	HQQE
Chromic acid H ₂ CrO ₄	H	1 %, 68 °F			HQQV	HQQV/HBQV
Citric acid HOC(CH ₂ CO ₂ H) ₂ COOH	H	5 %, 104 °F			HQQE	HQQE/HBQE
Completely desalinated water (demineralized water)		< 248 °F			HQQE	HQQE/HBQE
Condensate		< 194 °F	HQQE	HQQE/HBQE		
Copper sulfate CuSO ₄	E	10 %, 122 °F			HQQE	HQQE
Corn oil	D, E, 3	100 %, 176 °F	HQQV	HQQV/HBQV		
Diesel oil	2, 3, 4, F	100 %, 68 °F	HQB	HQQV/HBQV		
Domestic hot water (potable water)		< 248 °F	HQQE	HQQE/HBQE		
Ethanol (ethyl alcohol) C ₂ H ₅ OH	1, F	100 %, 68 °F	HQQE	HQQE/HBQE		
Ethylene glycol HOCH ₂ CH ₂ OH	D, E	50 %, 122 °F	HQQE	HQQE		
Formic acid HCOOH		5 %, 68 °F			HQQE	HQQE/HBQE
Glycerine (glycerol) OHCH ₂ CH(OH)CH ₂ OH	D, E	50 %, 122 °F	HQQE	HQQE/HBQE		
Hydraulic oil (mineral)	E, 2, 3	100 %, 212 °F	HQQV	HQQV/HBQV		
Hydraulic oil (synthetic)	E, 2, 3	100 %, 212 °F	HQQV	HQQV/HBQV		
Isopropyl alcohol CH ₃ CHOHCH ₃	1, F	100 %, 68 °F	HQB	HQQV/HBQV		
Lactic acid CH ₃ CH(OH)COOH	E, H	10 %, 68 °F			HQQE	HQQE/HBQE
Linoleic acid C ₁₇ H ₃₃ COOH	E, 3	100 %, 68 °F	HQQV	HQQV/HBQV		
Methanol (methyl alcohol) CH ₃ OH	1, F	100 %, 68 °F	HQQE	HQQE/HBQE		
Motor oil	E, 2, 3	100 %, 176 °F	HQQV	HQQV/HBQV		
Naphthalene C ₁₀ H ₈	E, H	100 %, 176 °F	HQQV	HQQV/HBQV		
Nitric acid HNO ₃	F	1 %, 68 °F			HQQE	HQQE/HBQE
Oil-containing water		< 212 °F	HQQV	HQQV/HBQV		
Olive oil	D, E, 3	100 %, 176 °F	HQQV	HQQV/HBQV		
Oxalic acid (COOH) ₂	H	1 %, 68 °F			HQQE	HQQE/HBQE
Ozone-containing water (O ₃)		1 PPM, < 105 °F			HQQE	HQQE/HBQE
Peanut oil	D, E, 3	100 %, 194 °F	HQQV	HQQV/HBQV		
Petrol/gasoline	1, 3, 4, F	100 %, 68 °F	HQB	HQQV/HBQV		
Phosphoric acid H ₃ PO ₄	E	20 %, 68 °F			HQQV	HQQV/HBQV
Propanol C ₃ H ₇ OH	1, F	100 %, 68 °F	HQQV	HQQV/HBQV		
Propylene glycol CH ₃ CH(OH)CH ₂ OH	D, E	50 %, 194 °F	HQQE	HQQE		
Potassium carbonate K ₂ CO ₃	E	20 %, 122 °F	HQQE	HQQE		
Potassium formate (as coolant with inhibitor) KOOCH	D, E	30 %, 122 °F	HQQE	HQQE		
Potassium hydroxide KOH	E	20 %, 122 °F			HQQE	HQQE
Potassium permanganate KmnO ₄		5 %, 68 °F			HQQE	HQQE/HBQE
Rape seed oil	D, E, 3	100 %, 176 °F	HQQV	HQQV/HBQV		
Salicylic acid C ₆ H ₄ (OH)COOH	H	0,1 %, 68 °F			HQQE	HQQE/HBQE
Silicone oil	E, 3	100 %	HQQV	HQQV/HBQV		
Sodium bicarbonate NaHCO ₃	E	10 %, 140 °F			HQQE	HQQE/HBQE
Sodium chloride (as coolant) NaCl	D, E	30 %, < 41 °F, pH > 8	HQQE	HQQE		
Sodium hydroxide NaOH	E	20 %, 122 °F			HQQE	HQQE
Sodium hypochlorite NaOCl	F	0,1 %, 68 °F			HQQE	HQQE
Sodium nitrate NaNO ₃	E	10 %, 140 °F			HQQE	HQQE/HBQE

Pumped liquid	Note	Liquid concentration, liquid temperature	CR		CRN	
			1s, 1, 3, 5, 10, 15, 20	32, 45, 64, 90, 120, 150	1s, 1, 3, 5, 10, 15, 20	32, 45, 64, 90, 120, 150
Sodium phosphate Na_3PO_4	E, H	10 %, 140 °F			HQQE	HQQE
Sodium sulfate Na_2SO_4	E, H	10 %, 140 °F			HQQE	HQQE/HBQE
Softened water		< 248 °F			HQQE	HQQE/HBQE
Soybean oil	D, E, 3	100 %, 176 °F	HQQV	HQQV/HBQV		
Sulfuric acid H_2SO_4	F	1 %, 68 °F			HQQV	HQQV/HQQV
Sulfurous acid H_2SO_3		1 %, 68 °F			HQQE	HQQE/HBQE
Swimming pool water (low chloride)		Max 5 ppm free chlorine (Cl_2)	HQQE	HQQE/HBQE		

Working and inlet pressure

Max. working pressure and temperature range

Oval flange

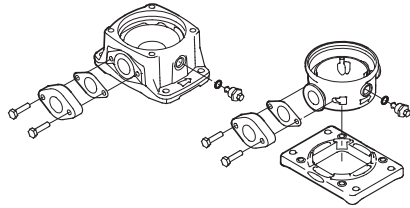

TM02 1379 1101

	Max. working pressure [psi]	Liquid temp. range [°F]
CR, CRI, CRN 1s	232	-4 to +248
CR, CRI, CRN 1	232	-4 to +248
CR, CRI, CRN 3	232	-4 to +248
CR, CRI, CRN 5	232	-4 to +248
CR 10-1 → CR 10-6	145	-4 to +248
CRI, CRN 10-1 → CRI, CRN 10-10	232	-4 to +248
CR 15-1 → CR 15-5	145	-4 to +248
CRI, CRN 15-1 → CRI, CRN 15-8	232	-4 to +248
CR 20-1 → CR 20-5	145	-4 to +248
CRI, CRN 20-1 → CRI, CRN 20-7	232	-4 to +248

ANSI, Clamp, PJE

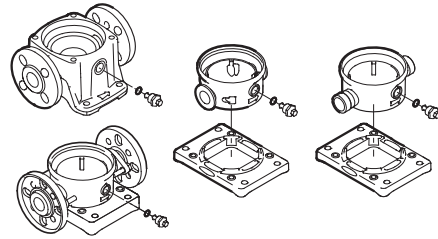

TM02 8835 0904

	Max. working pressure [psi]	Liquid temp. range [°F]
CR, CRI, CRN 1s	362	-4 to +248
CR, CRI, CRN 1	362	-4 to +248
CR, CRI, CRN 3	362	-4 to +248
CR, CRI, CRN 5	362	-4 to +248
CR, CRI 10-1 → 10-10	232	-4 to +248
CR, CRI 10-12 → 10-17	362	-4 to +248
CRN 10 (all stages)	362	-4 to +248
CR, CRI 15-1 → 15-8	232	-4 to +248
CR, CRI 15-9 → 15-12	362	-4 to +248
CRN 15 (all stages)	362	-4 to +248
CR, CRI 20-1 → 20-7	232	-4 to +248
CR, CRI 20-8 → 20-10	362	-4 to +248
CRN 20 (all stages)	362	-4 to +248
CR, CRN 32-1-1 → 2-5	232	-22 to +248
CR, CRN 32-6-2 → 32-11-2	435	-22 to +248
CR, CRN 45-1-1 → 45-4-2	232	-22 to +248
CR, CRN 45-4-1 → 45-8-1	435	-22 to +248
CR, CRN 64-1-1 → 64-3	232	-22 to +248
CR, CRN 64-4-2 → 64-5-2	435	-22 to +248
CR, CRN 90-1-1 → 90-3	232	-22 to +248
CR, CRN 90-4-2 → 90-4-1	435	-22 to +248
CR, CRN 120-1-1 → 120-5-1	435	-22 to +248
CR, CRN 150-1-1 → 150-4-1	435	-22 to +248

Operating range of the shaft seal

The operating range of the shaft seal depends on operating pressure, pump type, type of shaft seal and liquid temperature. The following curves apply to clean water and water with anti-freeze liquids. For selecting the right shaft seal, see *Pumped liquids* on page 13.

CR 1s - CR 20

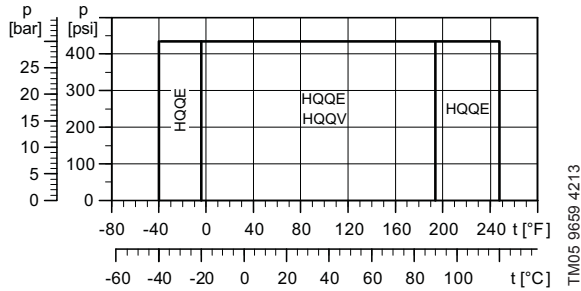

Fig. 5 Operating range of standard shaft seals for CR 1s - CR 20

CR 32 - CR 150 (3.0-60 Hp)

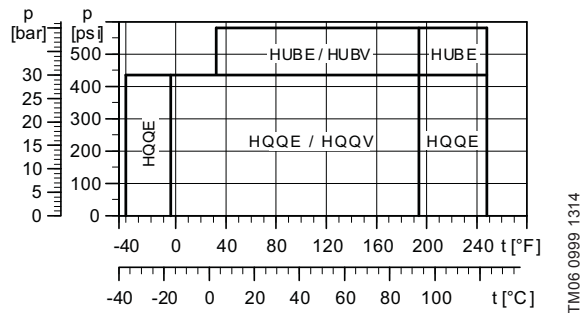

Fig. 6 Operating range of standard shaft seals for CR 32 - CR 150 (3.0-60 Hp)

CR 120 - CR 150 (75-100 Hp)

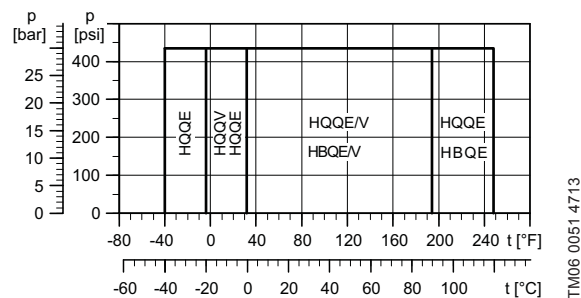

Fig. 7 Operating range of standard shaft seals for CR 120 - CR 150 (75-100 Hp)

Shaft seal	Description	Max. temp. range [°F]
HQQE	O-ring (cartridge) (balanced seal), SiC/SiC, EPDM	-40 °F to +248 °F
HBQE	O-ring (cartridge) (balanced seal), Carbon/SiC, EPDM	+32 °F to +248 °F
HBQV	O-ring (cartridge) (balanced seal), Carbon/SiC, FKM	+32 °F to +194 °F
HQQV	O-ring (cartridge) (balanced seal), SiC/SiC, FKM	-4 °F to +194 °F
HUBE	O-ring (cartridge) (balanced seal), TC/carbon, EPDM	+32 °F to +248 °F
HUBV	O-ring (cartridge) (balanced seal), TC/carbon, FKM	+32 °F to +194 °F

Note: TC= tungsten carbide

See section *Lists of variants - on request* on page 77, in case of extreme temperatures:

- low temperatures down to -40 °F or
- high temperatures up to +356 °F.

Maximum inlet pressure

The following table shows the maximum permissible inlet pressure. However, the current inlet pressure + the pressure against a closed valve **must** always be lower than the maximum permissible operating pressure.

If the maximum permissible operating pressure is exceeded, the bearing in the motor may be damaged and the life of the shaft seal reduced.

Pump type	Stages		Max. [psi (bar)]
	60 Hz	50 Hz	
CR, CRI, CRN 1s	2-27	2-36	145 (10)
CR, CRI, CRN 1	2-25	2-36	145 (10)
	27		217 (15)
CR, CRI, CRN 3	2-17	2-29	145 (10)
	19-25	31-36	217 (15)
CR, CRI, CRN 5	2-9	3-16	145 (10)
	10-24	18-36	217 (15)
CR, CRI, CRN 10	1-5	1-6	116 (8)
	6-17	7-22	145 (10)
CR, CRI, CRN 15	1-2	1-3	116 (8)
	3-12	4-17	145 (10)
CR, CRI, CRN 20	1	1-3	116 (8)
	2-10	4-17	145 (10)
CR, CRN 32	1-1 - 2	1-1 - 4	58 (4)
	3-2 - 6	5-2 - 10	145 (10)
	7-2 - 11-2	11-14	217 (15)
CR, CRN 45	1-1 - 1	1-1 - 2	58 (4)
	2-2 - 3	3-2 - 5	145 (10)
	4-2 - 8-1	6-2 - 13-2	217 (15)
CR, CRN 64	1-1	1-1 - 2-2	58 (4)
	1 - 2-1	2-1 - 4-2	145 (10)
	2 - 5-2	4-1 - 8-1	217 (15)
CR, CRN 90		1-1 - 1	58 (4)
	1-1 - 1	2-2 - 3-2	145 (10)
	2-2 - 4-1	3-6	217 (15)
CR, CRN 120	1-1 - 1	1 - 2-1	145 (10)
	2-2 - 3	2 - 5-1	217 (15)
	4-1 - 5-1	6-1 - 7	290 (20)
CR, CRN 150	1-1	1-1 - 1	145 (10)
	1-2	2-1 - 4-1	217 (15)
	3-2 - 4-1	5-2 - 6	290 (20)

Example of operating and inlet pressures

The values for operating and inlet pressures shown in the tables must not be considered individually but must always be compared, see the following examples:

Example 1:

The following pump type has been selected: CR 3-10 A-A-A

Max. operating pressure: **232 psi**

Max. inlet pressure: **145 psi**

Discharge pressure against a closed valve: **139.2 psi**, see page 43.

This pump is not allowed to start at an inlet pressure of 145 psi, but at an inlet pressure of $232.0 - 139.2 = 92.8$ psi.

Example 2:

The following pump has been selected: CR 10-2 A-GJ-A

Max. operating pressure: **232 psi**

Max. inlet pressure: **116 psi**

Discharge pressure against a closed valve: **42 psi (97 ft)**, see page 49.

This pump is allowed to start at an inlet pressure of 116 psi, as the discharge pressure is only 42 psi, which results in an operating pressure of $116 + 42 = 158$ psi. On the contrary, the max. operating pressure of this pump is limited to 158 psi, as a higher operating pressure will require an inlet pressure of more than 116 psi.

In case the inlet or operating pressure exceeds the pressure permitted, see section [Lists of variants - on request](#) on page 77.

8. Selection and sizing

Selection of pumps

Selection of pumps should be based on

- The duty point of the pump (see section 1)
- Sizing data such as pressure loss as a result of height differences, friction loss in the pipework, pump efficiency etc. (see section 2)
- Pump materials (see section 3)
- Pump connections (see section 4)
- Shaft seal (see section 5).

1. Duty point of the pump

From a duty point it is possible to select a pump on the basis of the curve charts in the section 9. *Performance curves* starting on page 24.

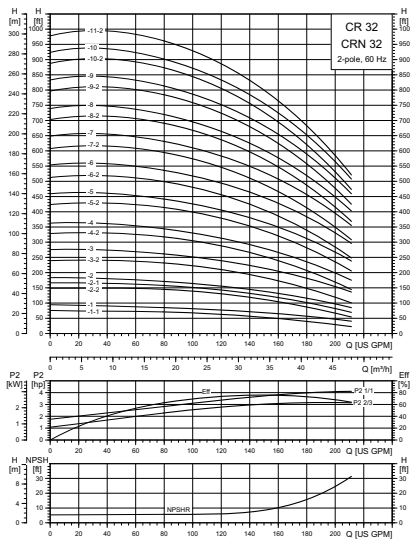

Fig. 8 Example of a curve chart

2. Sizing data

When sizing a pump the following must be taken into account.

- Required flow and pressure at the point of use.
- Pressure loss as a result of height differences (H_{geo}).
- Friction loss in the pipework (H_f).
It may be necessary to account for pressure loss in connection with long pipes, bends or valves, etc.
- Best efficiency at the estimated duty point.
- NPSH value.
For calculation of the NPSH value, see *Minimum inlet pressure - NPSHA* on page 22.

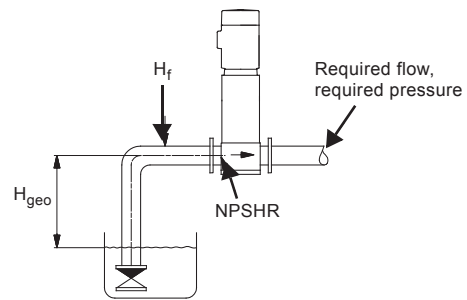

Fig. 9 Sizing data

Efficiency

Before determining the point of best efficiency the operation pattern of the pump needs to be identified. Is the pump expected to operate at the same duty point, then select a CR pump which is operating at a duty point corresponding with the best efficiency of the pump.

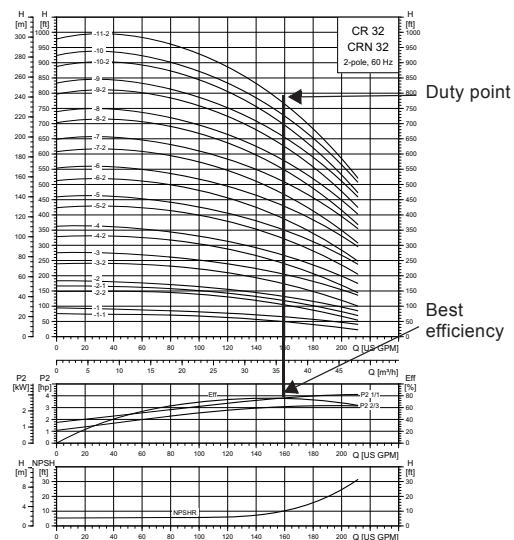

Fig. 10 Example of a CR pump's duty point

As the pump is sized on the basis of the highest possible flow, it is important to always have the duty point to the right of the optimum efficiency point (see fig. 11, range with check mark). This must be considered in order to keep efficiency high when the flow drops.

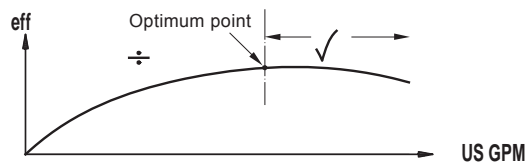

Fig. 11 Best efficiency

TM02 6711 1403

TM02 0039 4713

TM02 0039 1303

TM02 8579 0504

Normally, pumps with an external variable frequency drive (VFD) are used in applications characterized by a variable flow. Consequently, it is not possible to select a pump that is constantly operating at optimum efficiency.

In order to achieve optimum operating economy, the pump should be selected on the basis of the following criteria:

- The max. required duty point should be as close as possible to the QH curve of the pump.
- The required duty point should be positioned so that P2 is close to the max. point of the 100 % curve.

Between the min. and max. performance curves, pumps with a VFD have an infinite number of performance curves each representing a specific speed. Therefore it may not be possible to select a duty point close to the 100 % curve.

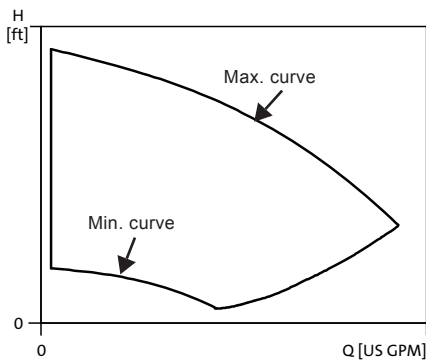

Fig. 12 Min. and max. performance curves

In situations where it is not possible to select a duty point close to the 100 % curve the affinity equations to the right can be used. The head (H), the flow (Q) and the input power (P) are all the appropriate variables for the motor speed (n).

Note:

The approximated formulas apply on condition that the system characteristic remains unchanged for n_n and n_x and that it is based on the formula $H = k \times Q^2$, where k is a constant.

The power equation implies that the pump efficiency is unchanged at the two speeds. In practice this is **not** quite correct.

Finally, it is worth noting that the efficiencies of the frequency converter and the motor **must** be taken into account if a precise calculation of the power saving resulting from a reduction of the pump speed is wanted.

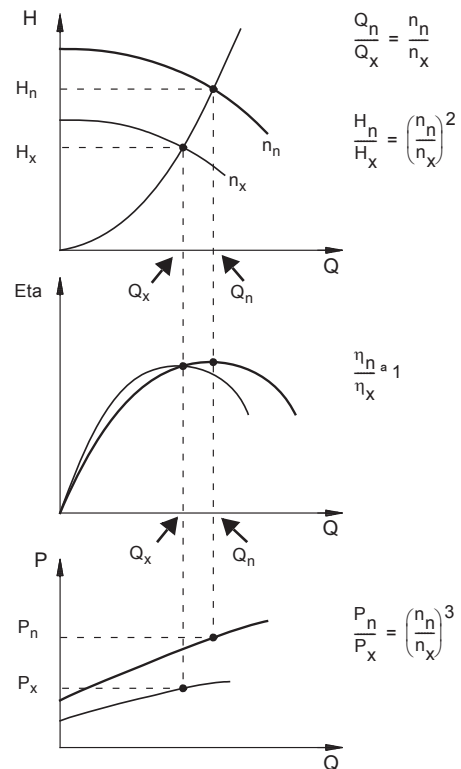

Fig. 13 Affinity equations

Legend

H_n	Rated head in feet
H_x	Current head in feet
Q_n	Rated flow in US gpm
Q_x	Current flow in US gpm
n_n	Rated motor speed in min^{-1} ($n_n = 3500 \text{ min}^{-1}$)
n_x	Current motor speed in min^{-1}
η_n	Rated efficiency in %
η_x	Current efficiency in %

TM02 7572 4803

TM00 8720 3496

WinCAPS and WebCAPS

WinCAPS and WebCAPS are both selection programs offered by Grundfos.

The two programs make it possible to calculate a pump's specific duty point and energy consumption. By entering the sizing data of the pump, WinCAPS and WebCAPS can calculate the exact duty point and energy consumption. For further information see [16. Grundfos Product Center](#) on page 85.

3. Material

The material variant (CR, CRI, CRN) should be selected based on the liquid to be pumped. The product range covers three basic types.

- The CR, CRI pump types are suitable for clean, non-aggressive liquids such as potable water, oils, etc.
- The CRN pump type is suitable for industrial liquids and acids, see [Pumped liquids](#) on page 13 or contact Grundfos.

For saline or chloride-containing liquids such as sea water, CRT pumps of titanium are available.

4. Pump connection

Selection of pump connection depends on the rated pressure and pipework. To meet any requirement the CR, CRI and CRN pumps offer a wide range of flexible connections such as:

- Oval flange (NPT) - fig. 15
- ANSI flange - fig. 15
- PJE coupling - fig. 15
- Clamp coupling
- Union (NPT[M])
- Other connections on request.

5. Shaft seal

As standard, the CR range is fitted with a Grundfos shaft seal (Cartridge type) suitable for the most common applications, see fig. 16.

The following three key parameters **must** be taken into account, when selecting the shaft seal:

- Type of pumped liquid
- liquid temperature and
- Maximum pressure.

Grundfos offers a wide range of shaft seal variants to meet specific demands see [Pumped liquids](#) on page 13.

6. Inlet pressure and operating pressure

Do **not** exceed the limit values stated on page 16 and page 18 as regards these pressures:

- maximum inlet pressure and
- maximum operating pressure.

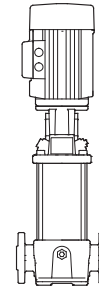

Fig. 14 CR pump

TM03 2155 3805

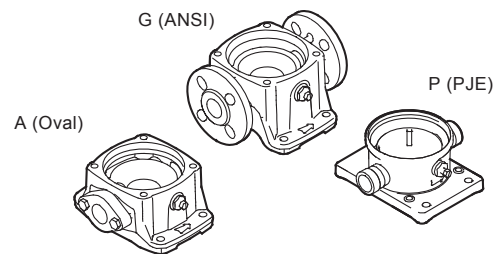

Fig. 15 Pump connections

TM02 1201 0601

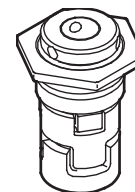

Fig. 16 Shaft seal (Cartridge type)

TM02 0538 4800

Minimum inlet pressure - NPSHA

Calculation of the inlet pressure "H" is recommended in these situations:

- The liquid temperature is high.
- The flow is significantly higher than the rated flow.
- Water is drawn from depths.
- Water is drawn through long pipes.
- Inlet conditions are poor.

To avoid cavitation, make sure that there is a minimum pressure on the suction side of the pump. The maximum suction lift "H" in feet can be calculated as follows:

$$H = P_b - \text{NPSHR} - H_f - H_v - H_s$$

P_b = Barometric pressure in feet absolute.
(Barometric pressure can be set to 33.9 feet. At sea level. In closed systems, p_b indicates system pressure in feet.)

NPSHR = Net Positive Suction Head Required in feet.
(To be read from the NPSHR curve at the highest flow the pump will be delivering.)

H_f = Friction loss in suction pipe in feet. (At the highest flow the pump will be delivering.)

H_v = Vapor pressure in feet. (To be read from the vapor pressure scale. " H_v " depends on the liquid temperature " T_m ").

H_s = Safety margin = minimum 2.0 feet.

If the "H" calculated is positive, the pump can operate at a suction lift of maximum "H" feet.

If the "H" calculated is negative, an inlet pressure of minimum "H" feet is required.

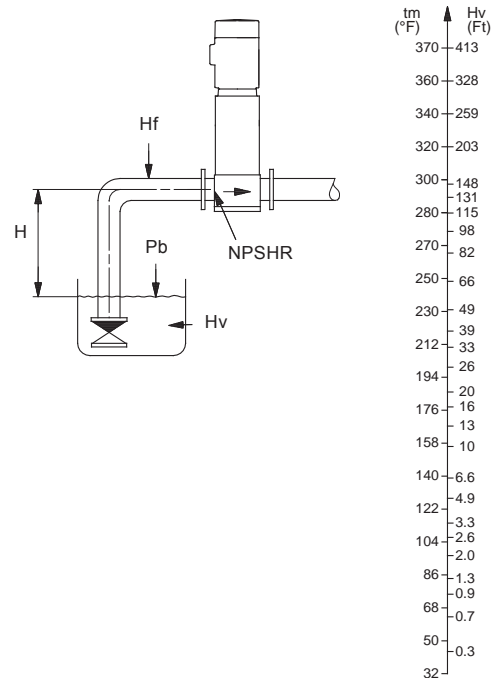

Fig. 17 Minimum inlet pressure - NPSHR

Note: In order to avoid cavitation **never**, select a pump whose duty point lies too far to the right on the NPSHR curve.

Always check the NPSHR value of the pump at the highest possible flow.

In case a lower NPSHR value is required, see [Lists of variants - on request](#) on page 77.

TM02 7729 3903

How to read the curve charts

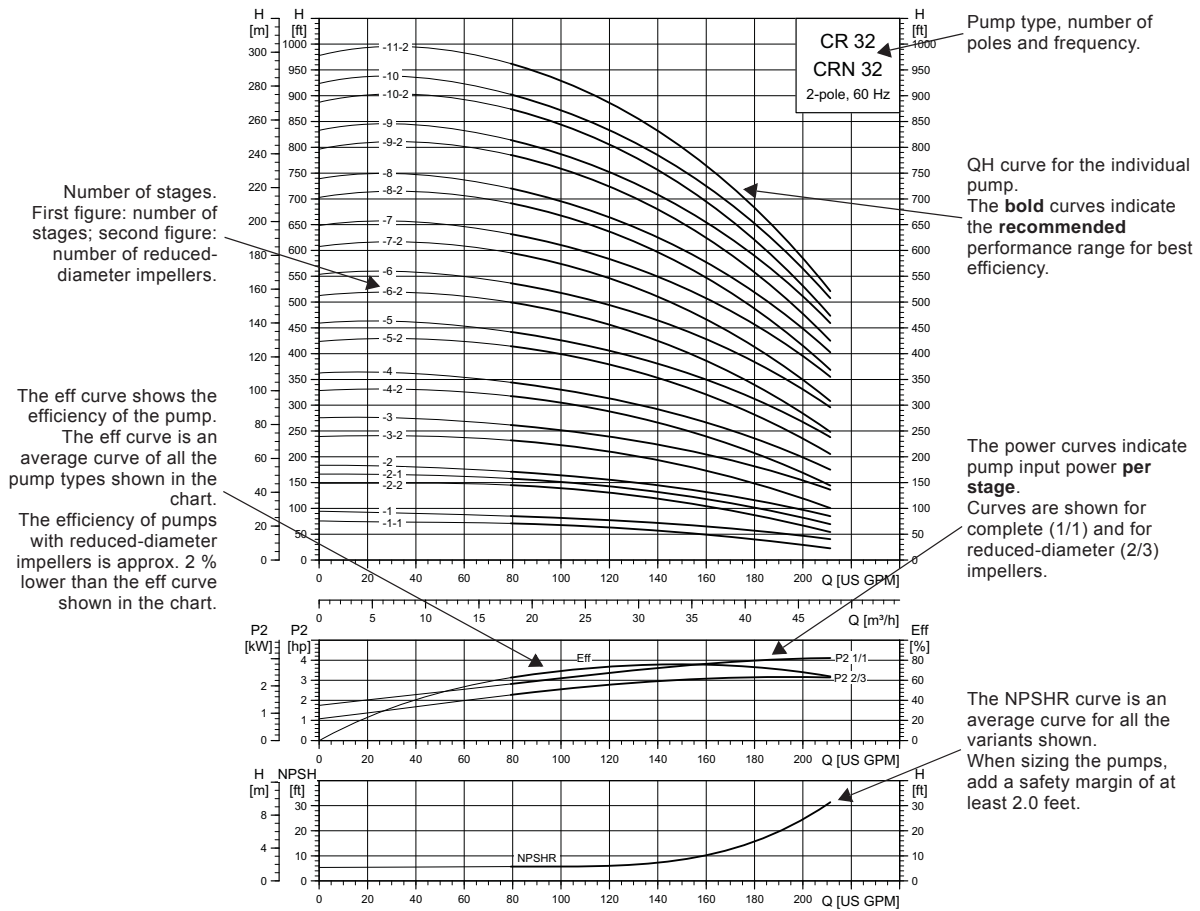

Fig. 18 How to read the curve charts

Guidelines to performance curves

The guidelines below apply to the curves shown on the following pages:

1. The motors used for the measurements are standard motors (ODP, TEFC).
2. Measurements have been made with airless water at a temperature of 68 °F (20 °C).
3. The curves apply to a kinematic viscosity of $\nu = 1 \text{ mm}^2/\text{s}$ (1 cSt).
4. Due to the risk of overheating, the pumps should not be used at a flow below the minimum flow rate.
5. The QH curves apply to actual speed with the motor types mentioned at 60 Hz.

The curve below shows the minimum flow rate as a percentage of the nominal flow rate in relation to the liquid temperature. The dotted line shows a CR pump fitted with an air-cooled top assembly.

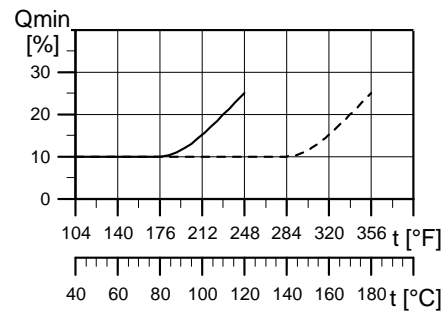

Fig. 19 Minimum flow rate

TM02 0039 4713

TM02 7538 3703

9. Performance curves

CR, CRI, CRN 1s

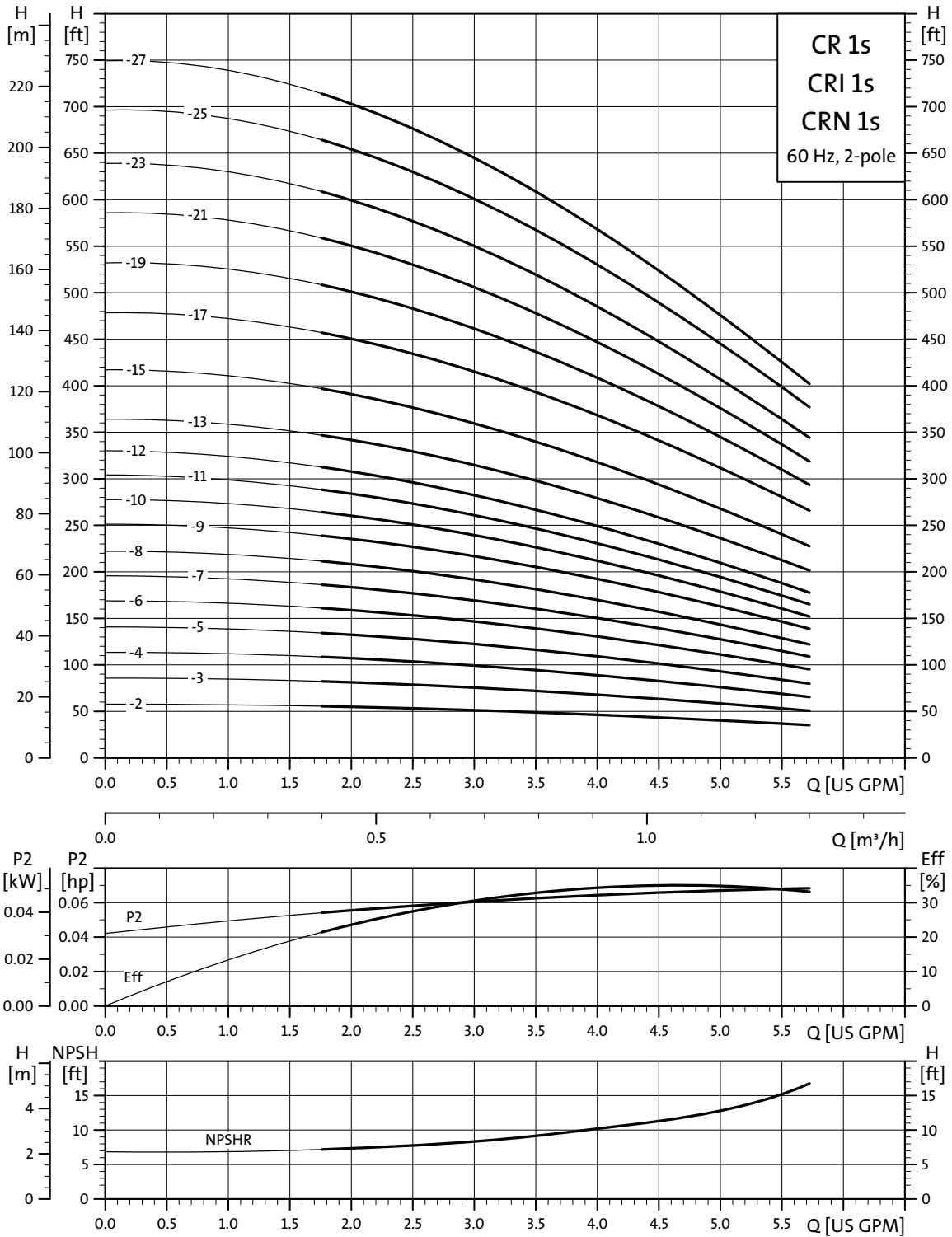

TM02 5741 1303

CR, CRI, CRN 1

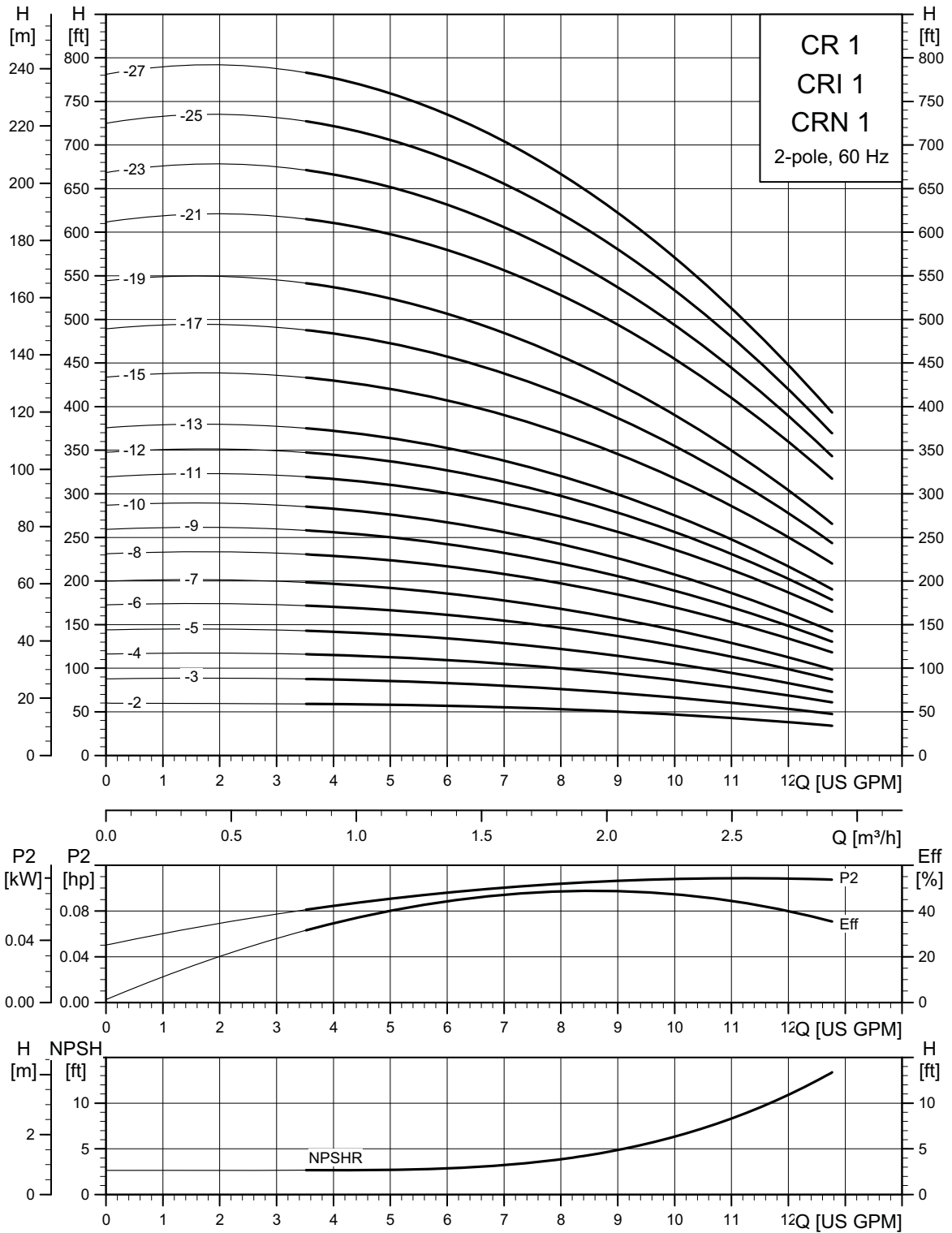

TM02 4083 4713

CR, CRI, CRN 3

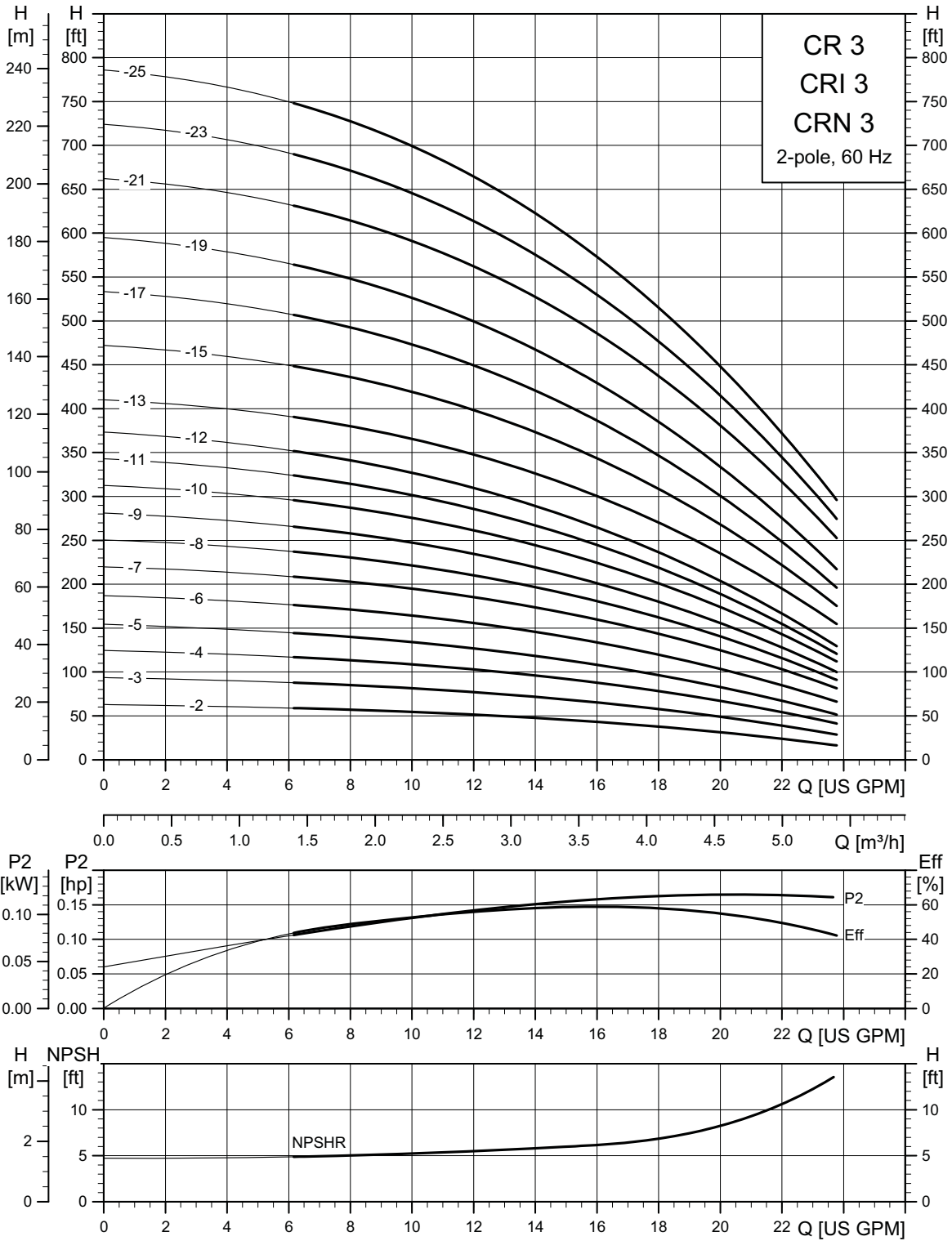

TM02 4084 4713

CR, CRI, CRN 5

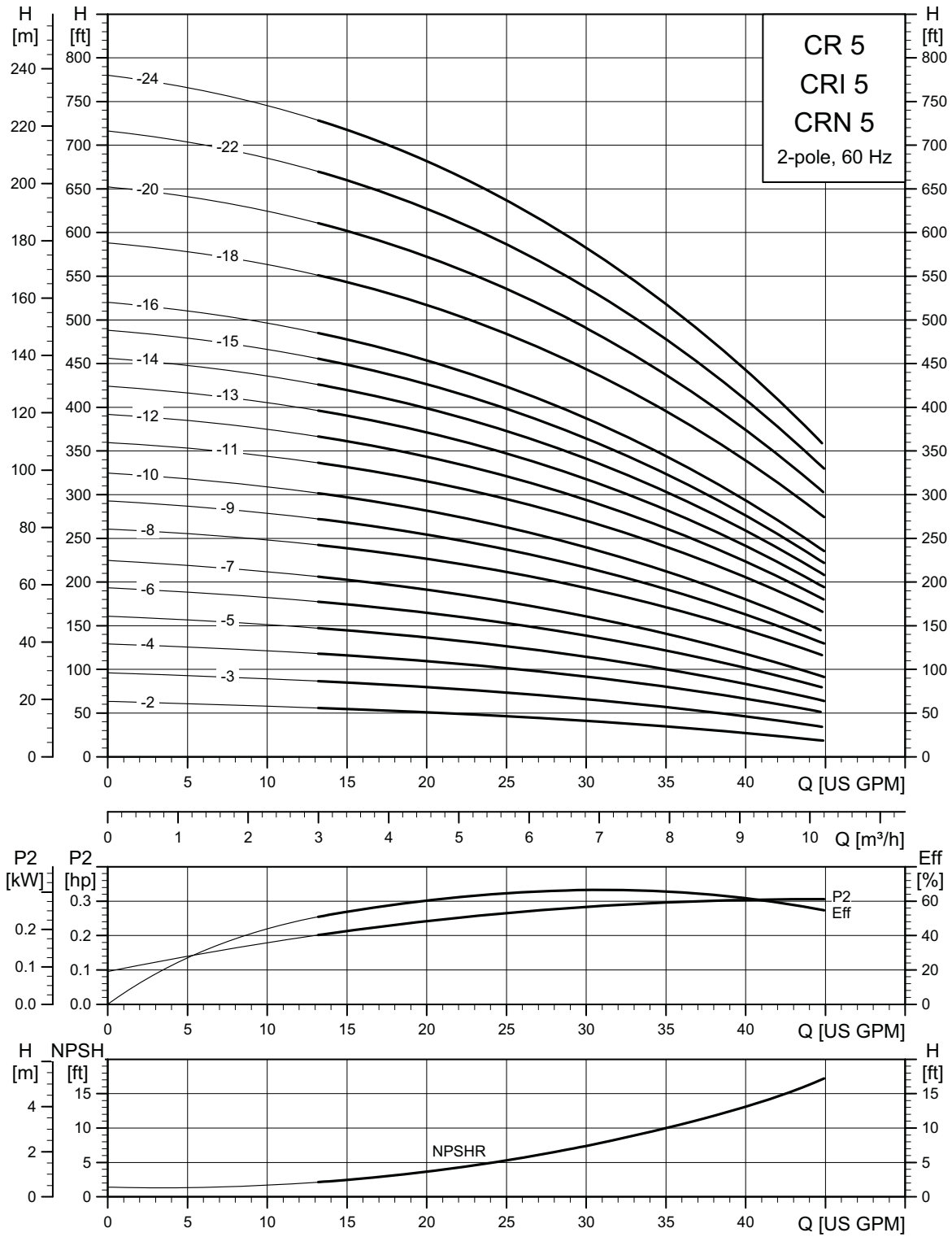

TM02 4085 4713

CR, CRI, CRN 10

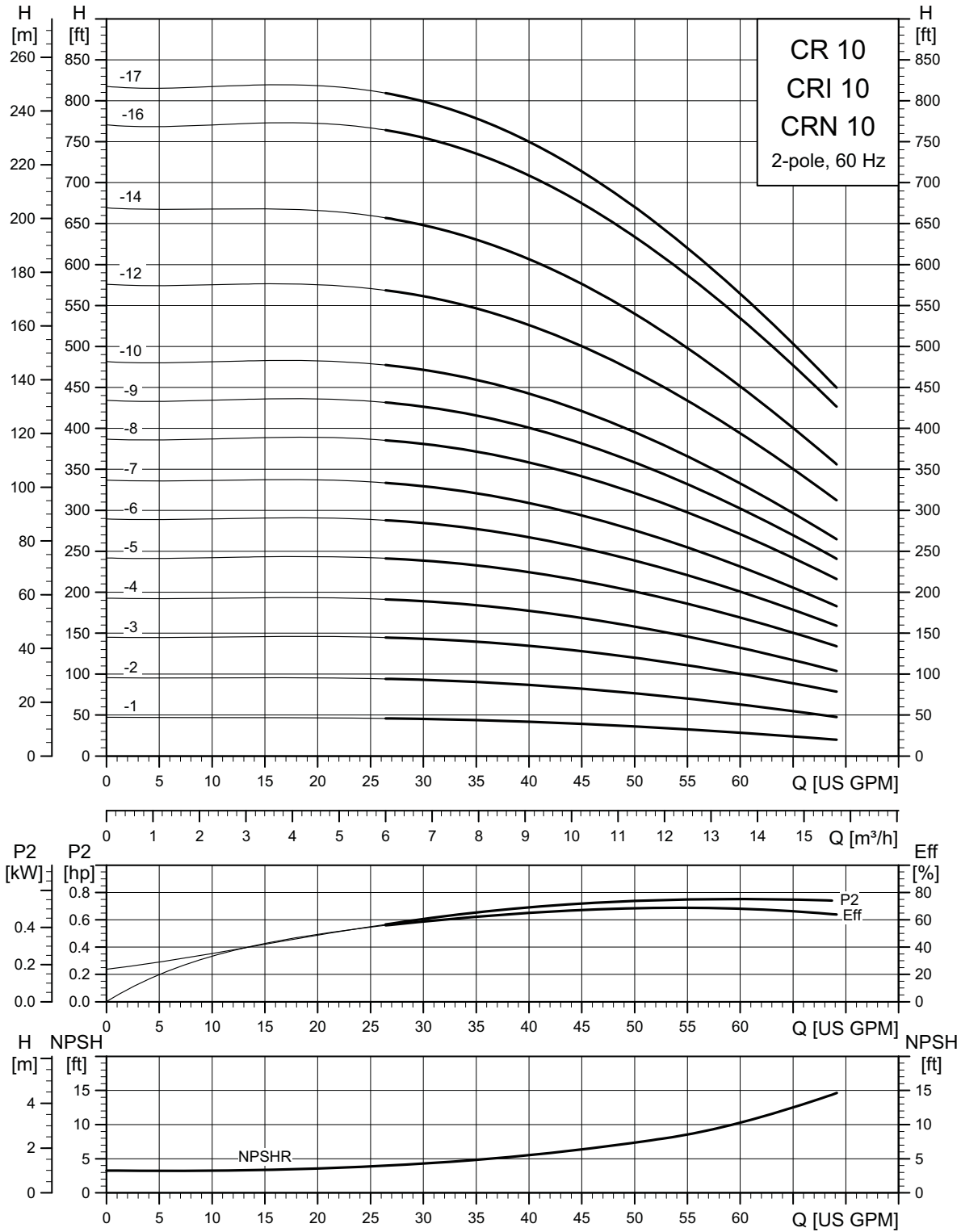

TM02 7221 47/13

CR, CRI, CRN 15

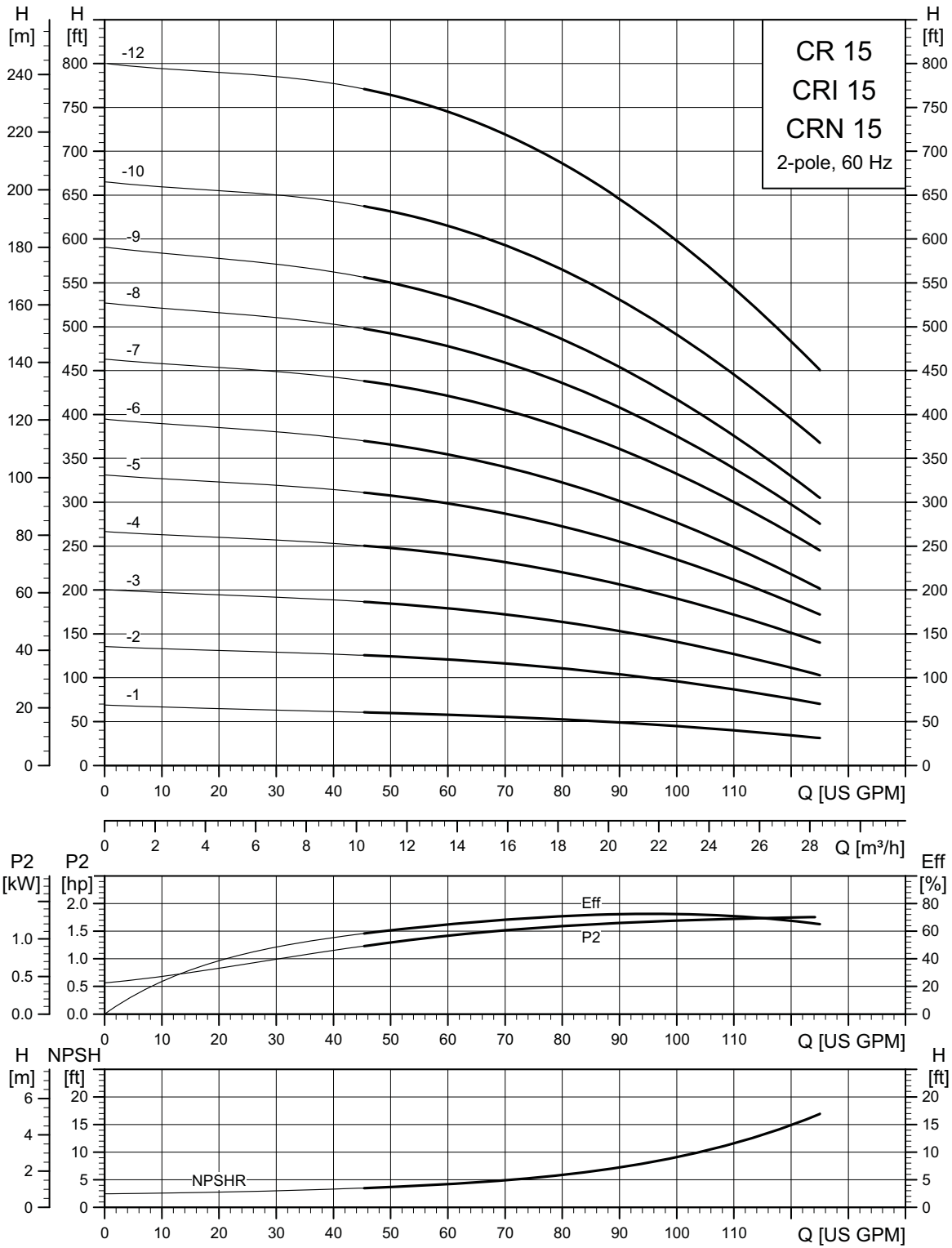

TM02 7222 4713

CR, CRI, CRN 20

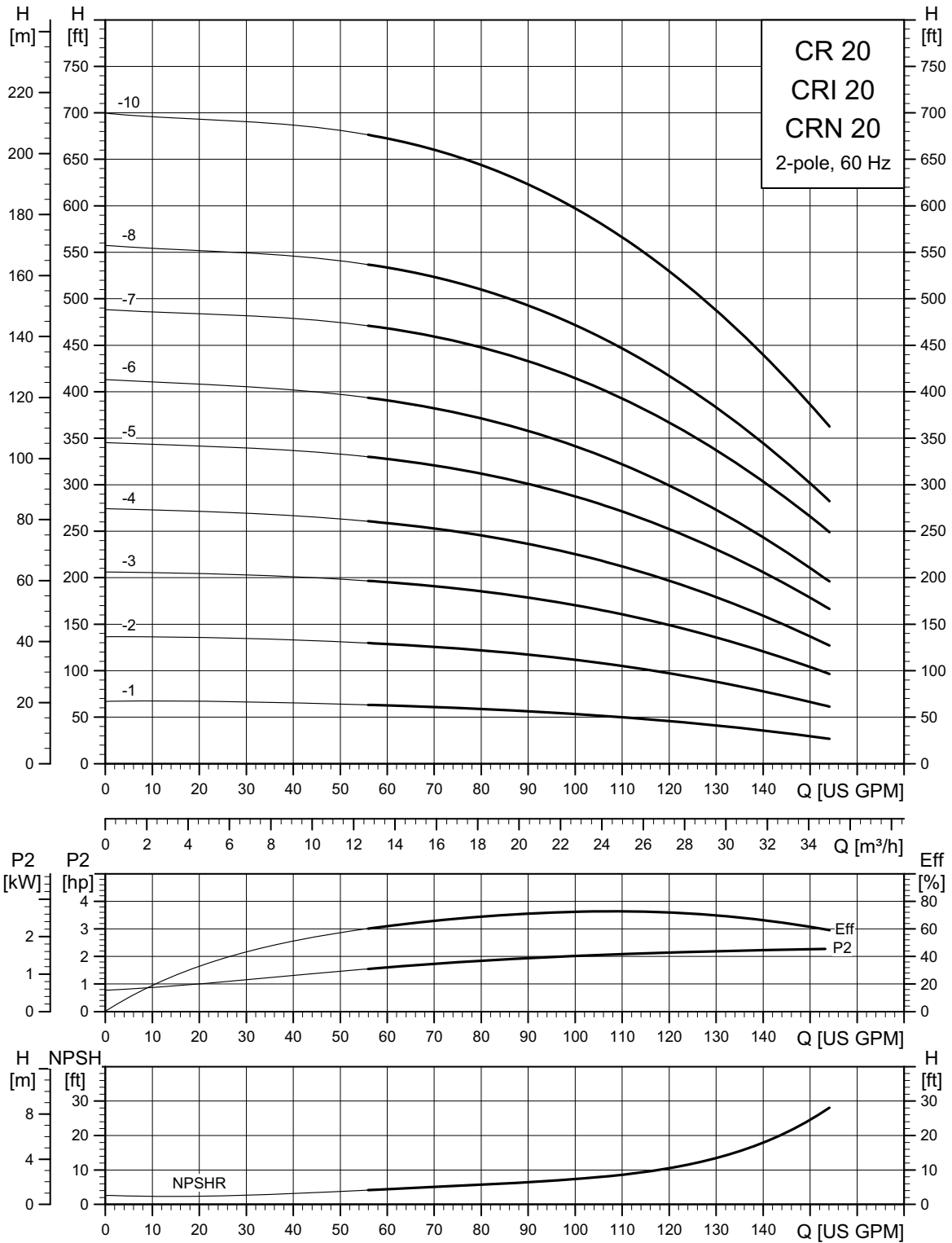

TM02 7223 4713

CR, CRN 32

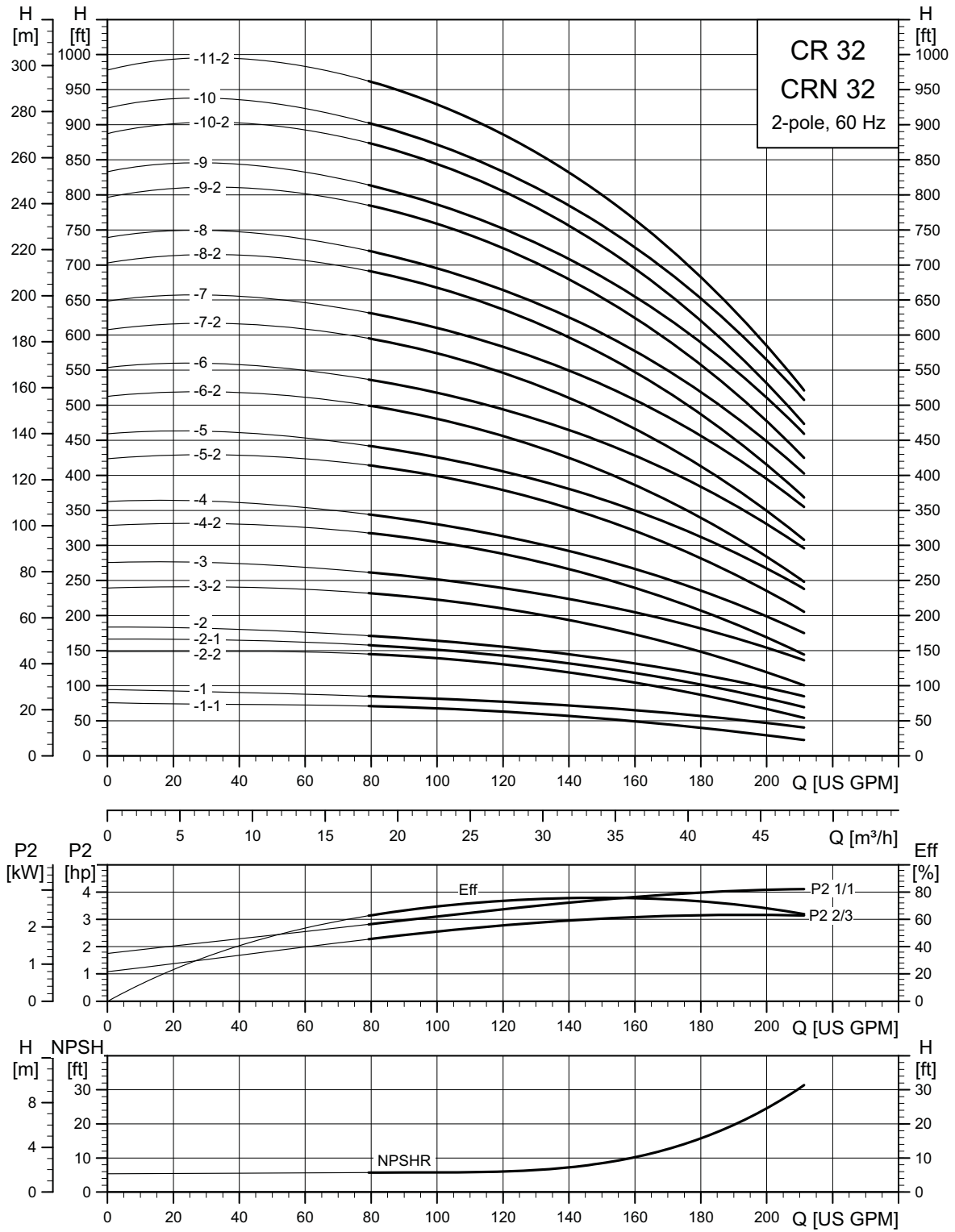

TM02 0039 4713

CR, CRN 45

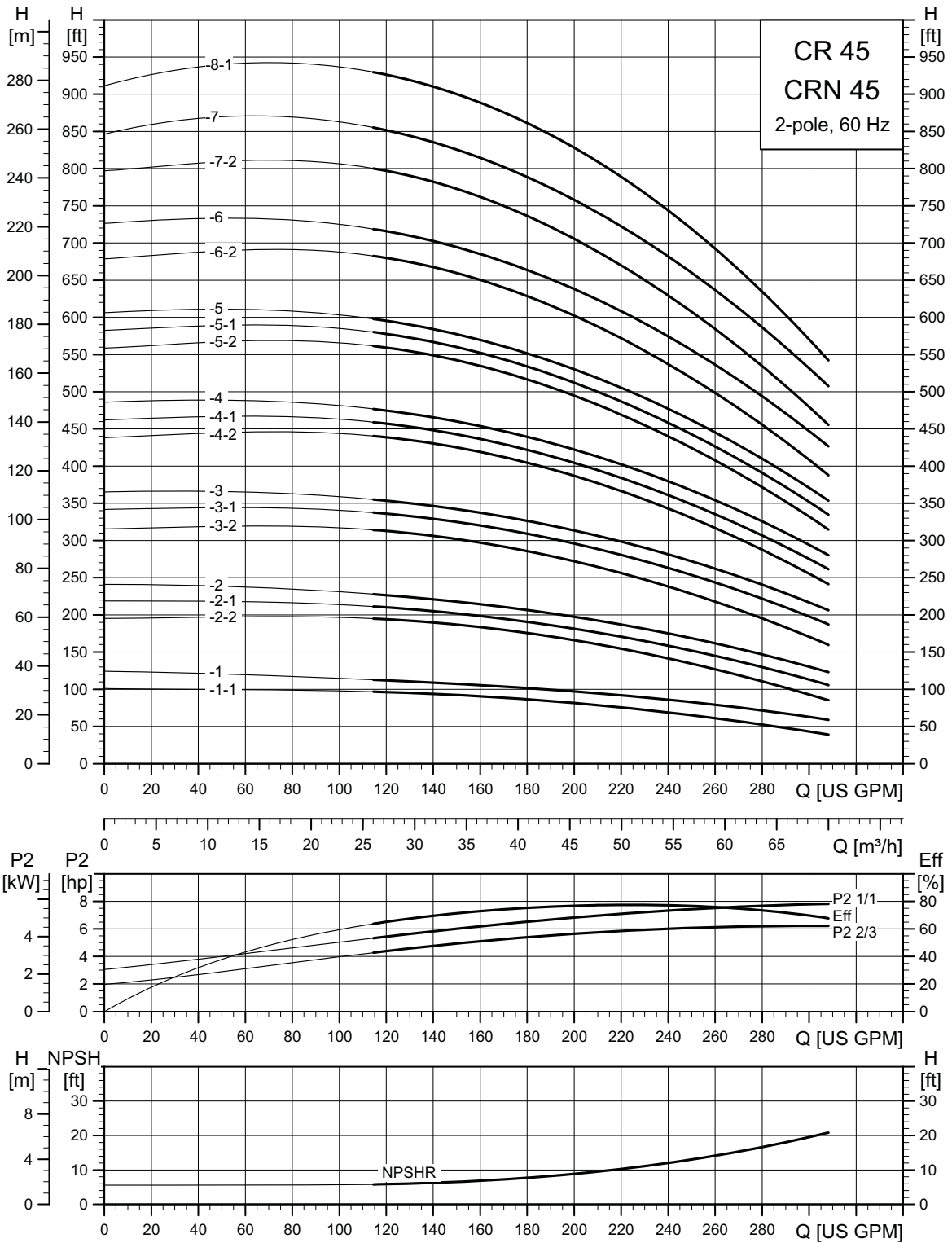

TM02 0040 4713

CR, CRN 64

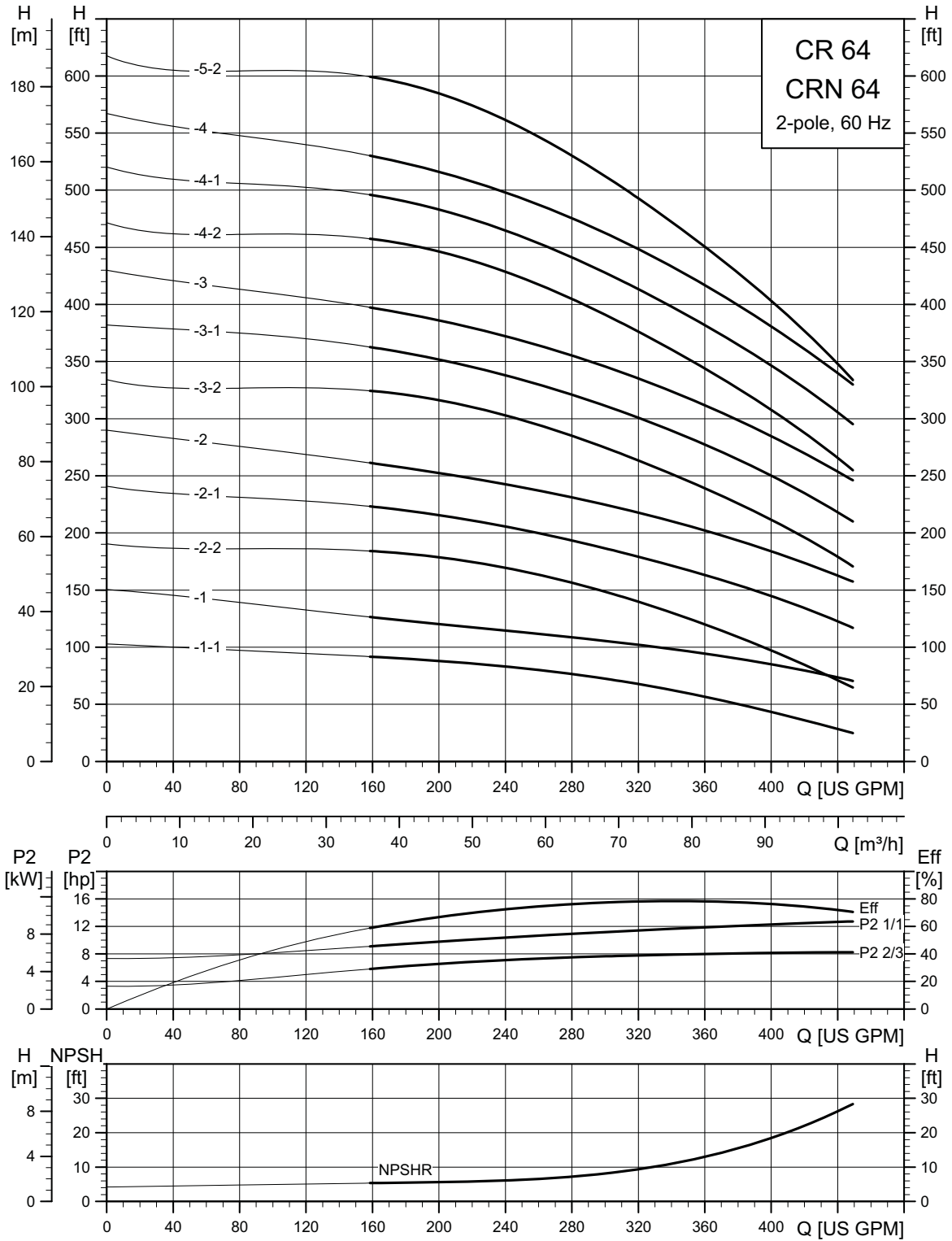

TM02 0041 4713

CR, CRN 90

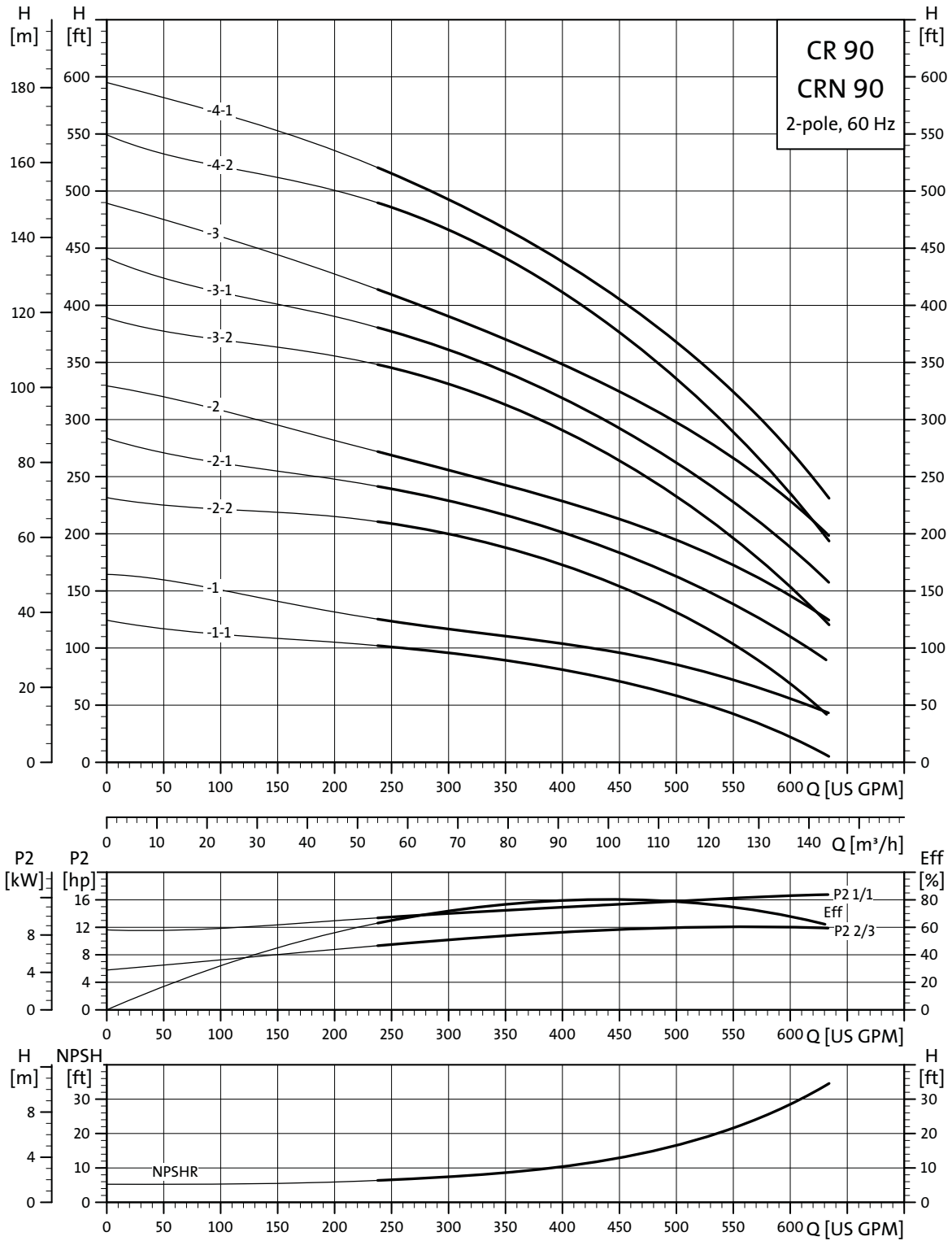

TM02 0042 1303

CR, CRN 120

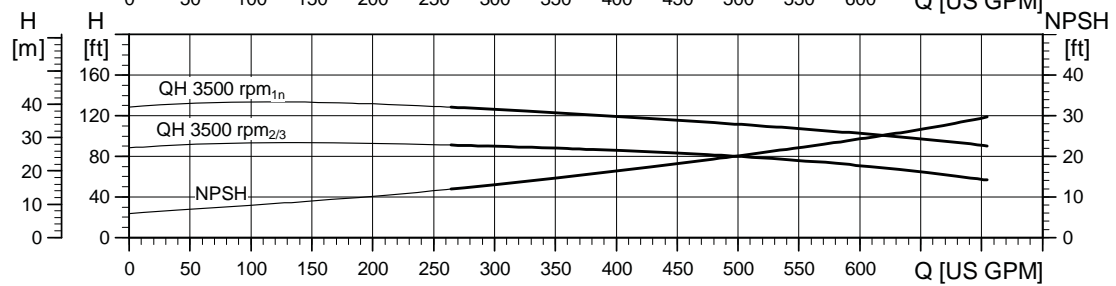
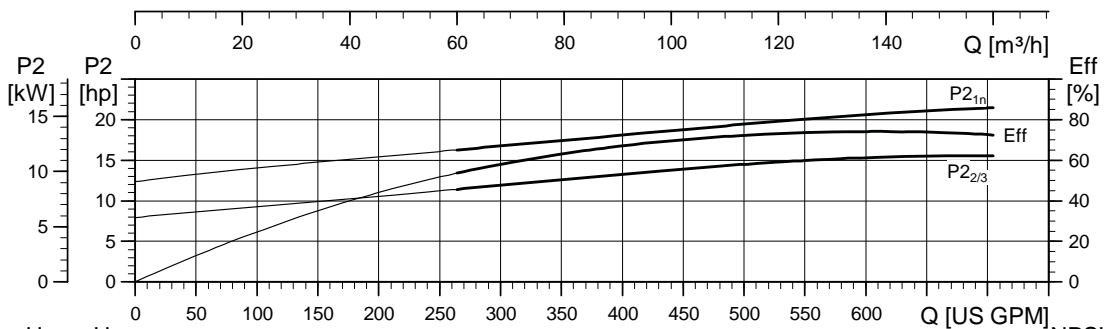
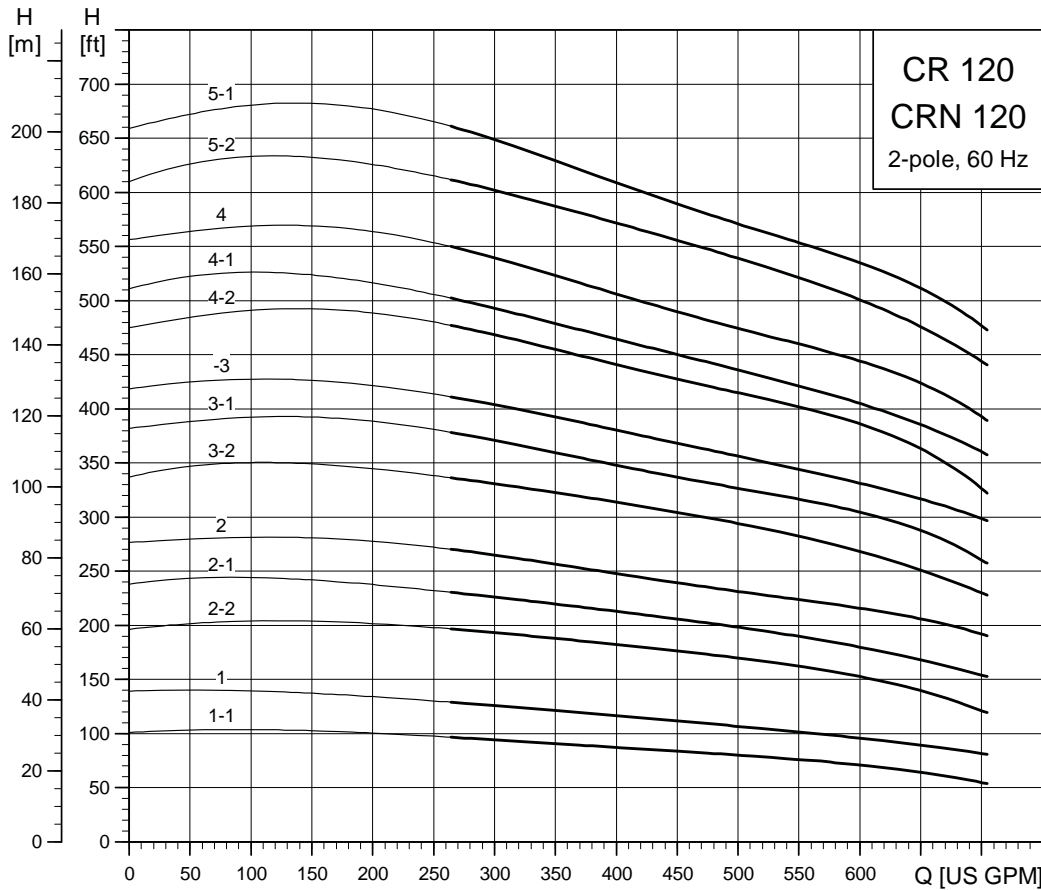

TM03 9192 0209

CR, CRN 150

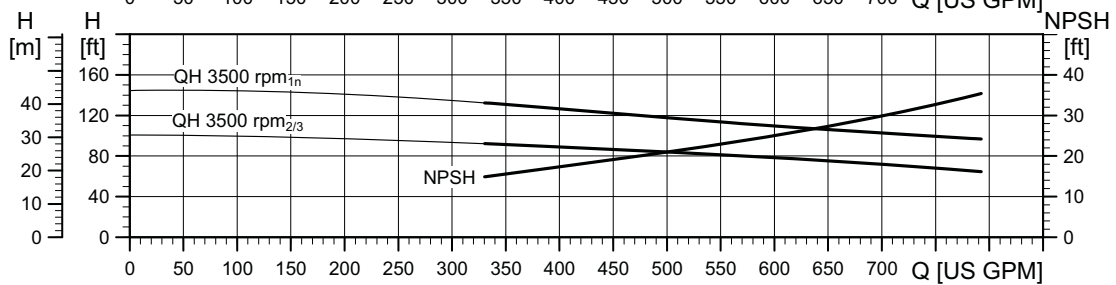
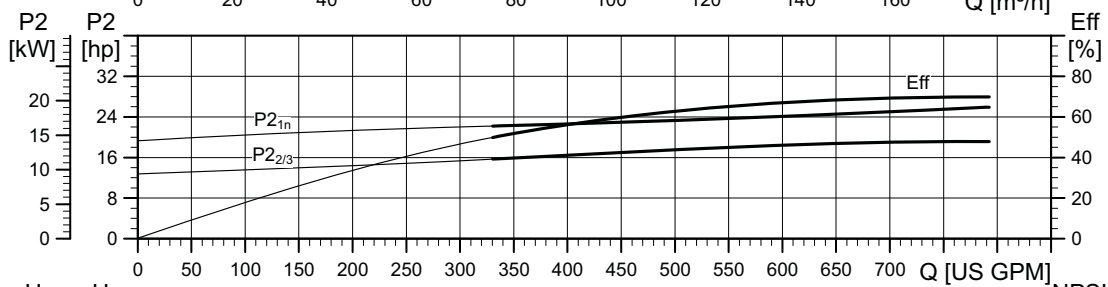
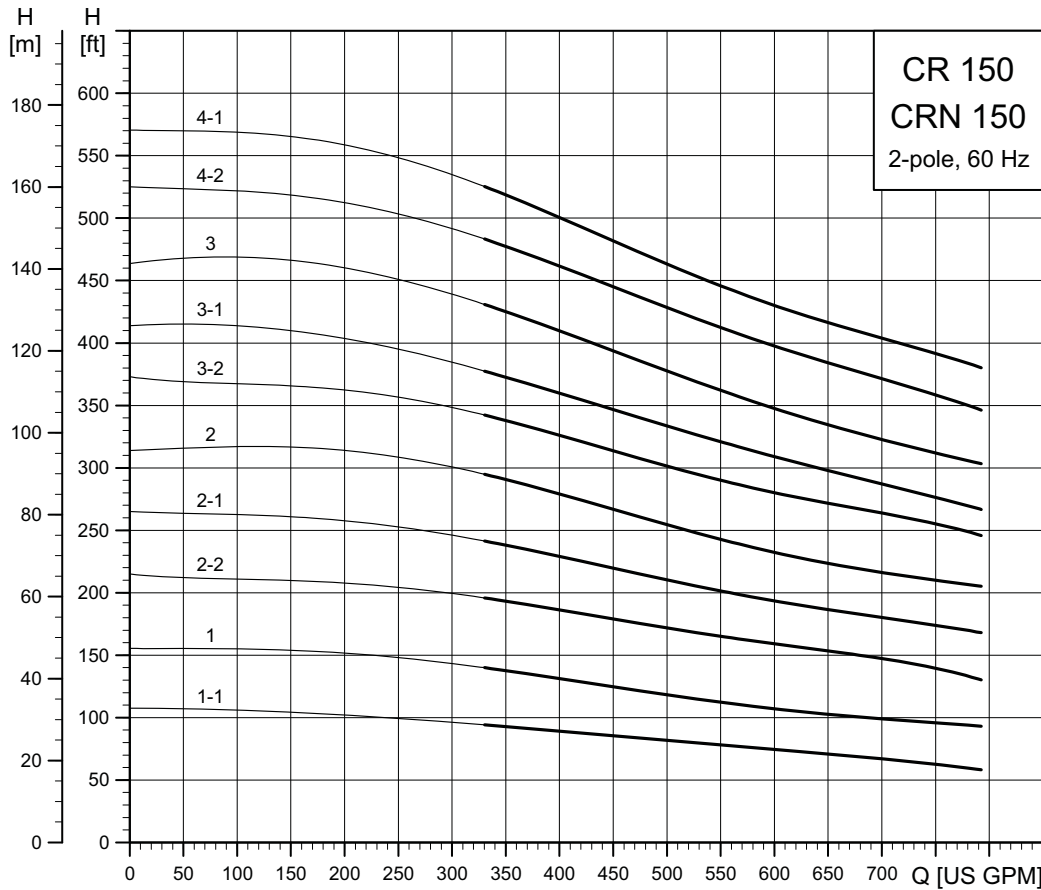

TM03 9193 42/13

10. Technical data

CR 1s

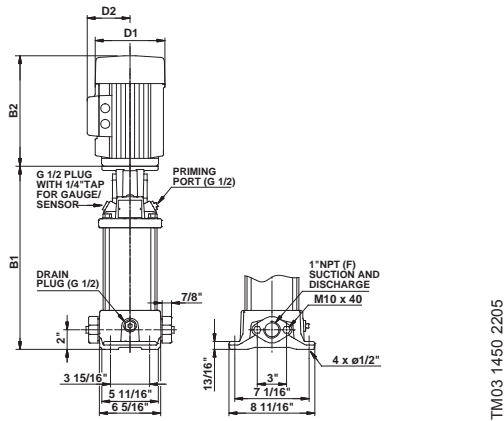

TM03 1450 2205

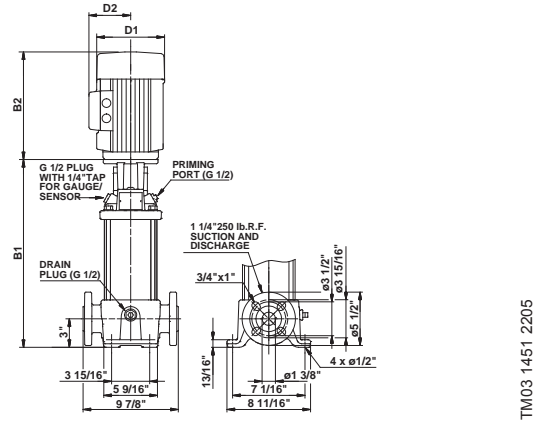

TM03 1451 2205

Pump type	P2 [Hp]	Ph.	Oval*	ANSI dimensions [inch (mm)]				Ship. wt. [lbs (kg)]
				B1	TEFC			
					D1	D2	B1+B2	
CR 1s-2	1/3	1	•	11.97 (305)	6.19 (158)	5.18 (132)	21.26 (541)	69 (32)
CR 1s-2	1/3	3	•	11.97 (305)	5.55 (141)	4.57 (117)	19.41 (494)	67 (31)
CR 1s-3	1/3	1	•	11.97 (305)	6.19 (158)	5.18 (132)	21.26 (541)	69 (32)
CR 1s-3	1/3	3	•	11.97 (305)	5.55 (141)	4.57 (117)	19.41 (494)	67 (31)
CR 1s-4	1/3	1	•	12.68 (323)	6.19 (158)	5.18 (132)	21.97 (559)	70 (32)
CR 1s-4	1/3	3	•	12.68 (323)	5.55 (141)	4.57 (117)	20.12 (512)	68 (31)
CR 1s-5	1/3	1	•	13.39 (341)	6.19 (158)	5.18 (132)	22.68 (577)	71 (33)
CR 1s-5	1/3	3	•	13.39 (341)	5.55 (141)	4.57 (117)	20.83 (530)	69 (32)
CR 1s-6	1/2	1	•	14.09 (358)	6.19 (158)	5.18 (132)	23.38 (594)	75 (35)
CR 1s-6	1/2	3	•	14.09 (358)	5.55 (141)	4.57 (117)	21.53 (547)	70 (32)
CR 1s-7	1/2	1	•	14.80 (376)	6.19 (158)	5.18 (132)	24.09 (612)	76 (35)
CR 1s-7	1/2	3	•	14.80 (376)	5.55 (141)	4.57 (117)	22.24 (565)	71 (33)
CR 1s-8	1/2	1	•	15.51 (394)	6.19 (158)	5.18 (132)	24.80 (630)	77 (35)
CR 1s-8	1/2	3	•	15.51 (394)	5.55 (141)	4.57 (117)	22.95 (583)	72 (33)
CR 1s-9	3/4	1	•	16.22 (412)	6.19 (158)	5.18 (132)	26.13 (664)	82 (38)
CR 1s-9	3/4	3	•	16.22 (412)	5.55 (141)	4.57 (117)	23.66 (601)	73 (34)
CR 1s-10	3/4	1	•	16.93 (431)	6.19 (158)	5.18 (132)	26.84 (682)	83 (38)
CR 1s-10	3/4	3	•	16.93 (431)	5.55 (141)	4.57 (117)	24.37 (619)	74 (34)
CR 1s-11	3/4	1	•	17.64 (449)	6.19 (158)	5.18 (132)	27.55 (700)	84 (39)
CR 1s-11	3/4	3	•	17.64 (449)	5.55 (141)	4.57 (117)	25.08 (638)	75 (35)
CR 1s-12	3/4	1	•	18.35 (467)	6.19 (158)	5.18 (132)	28.26 (718)	85 (39)
CR 1s-12	3/4	3	•	18.35 (467)	5.55 (141)	4.57 (117)	25.79 (656)	76 (35)
CR 1s-13	1	1	•	19.06 (485)	7.19 (183)	5.73 (146)	30.25 (769)	101 (46)
CR 1s-13	1	3	•	19.06 (485)	5.55 (141)	4.57 (117)	26.50 (674)	77 (35)
CR 1s-15	1	1	•	20.47 (520)	7.19 (183)	5.73 (146)	31.66 (805)	103 (47)
CR 1s-15	1	3	•	20.47 (520)	5.55 (141)	4.57 (117)	27.91 (709)	78 (36)
CR 1s-17	1 1/2	1	•	21.89 (557)	7.19 (183)	5.73 (146)	33.57 (853)	107 (49)
CR 1s-17	1 1/2	3	•	21.89 (557)	5.55 (141)	4.57 (117)	30.51 (775)	84 (39)
CR 1s-19	1 1/2	1	-	23.31 (593)	7.19 (183)	5.73 (146)	34.99 (889)	109 (50)
CR 1s-19	1 1/2	3	-	23.31 (593)	5.55 (141)	4.57 (117)	31.93 (812)	86 (40)
CR 1s-21	1 1/2	1	-	24.72 (628)	7.19 (183)	5.73 (146)	36.40 (925)	111 (51)
CR 1s-21	1 1/2	3	-	24.72 (628)	5.55 (141)	4.57 (117)	33.34 (847)	88 (40)
CR 1s-23	1 1/2	1	-	26.14 (664)	7.19 (183)	5.73 (146)	37.82 (961)	113 (52)
CR 1s-23	1 1/2	3	-	26.14 (664)	5.55 (141)	4.57 (117)	34.76 (883)	90 (41)
CR 1s-25	2	1	-	27.56 (701)	7.19 (183)	5.73 (146)	40.12 (1020)	126 (58)
CR 1s-25	2	3	-	27.56 (701)	7.01 (179)	4.33 (110)	38.78 (986)	116 (53)
CR 1s-27	2	1	-	28.98 (737)	7.19 (183)	5.73 (146)	41.54 (1056)	127 (58)
CR 1s-27	2	3	-	28.98 (737)	7.01 (179)	4.33 (110)	40.20 (1022)	118 (54)

All dimensions in inches unless otherwise noted.

* Oval flanged pump B1 and B1+B2 dimension is one inch less than ANSI flanged pump and weight is approximately 9 lbs. less.

- Available.

CRI 1s

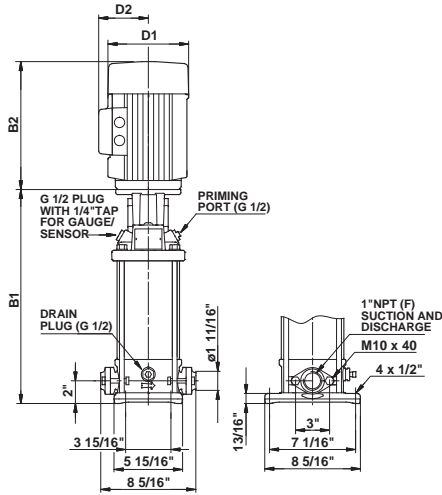

TM03 1452 2205

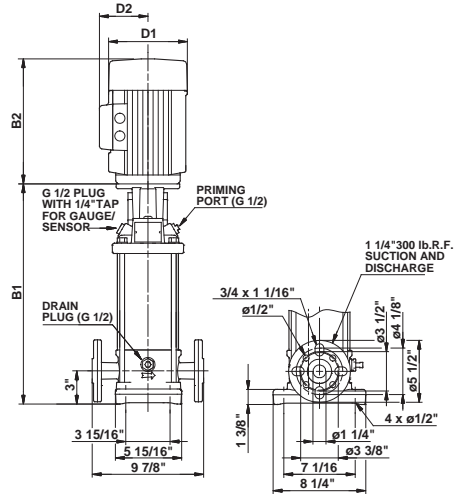

TM03 1453 2205

Pump type	P2 [Hp]	Ph.	Oval*	ANSI dimensions [inch (mm)]				Ship. wt. [lbs (kg)]
				B1	TEFC			
					D1	D2	B1+B2	
CRI 1s-2	1/3	1	●	12.09 (308)	6.19 (158)	5.18 (132)	21.38 (544)	64 (30)
CRI 1s-2		3	●	12.09 (308)	5.55 (141)	4.57 (117)	19.53 (497)	62 (29)
CRI 1s-3	1/3	1	●	12.09 (308)	6.19 (158)	5.18 (132)	21.38 (544)	64 (30)
CRI 1s-3		3	●	12.09 (308)	5.55 (141)	4.57 (117)	19.53 (497)	62 (29)
CRI 1s-4	1/3	1	●	12.80 (326)	6.19 (158)	5.18 (132)	22.09 (562)	65 (30)
CRI 1s-4		3	●	12.80 (326)	5.55 (141)	4.57 (117)	20.24 (515)	63 (29)
CRI 1s-5	1/3	1	●	13.50 (343)	6.19 (158)	5.18 (132)	22.79 (579)	66 (30)
CRI 1s-5		3	●	13.50 (343)	5.55 (141)	4.57 (117)	20.94 (532)	64 (30)
CRI 1s-6	1/2	1	●	14.21 (361)	6.19 (158)	5.18 (132)	23.50 (597)	70 (32)
CRI 1s-6		3	●	14.21 (361)	5.55 (141)	4.57 (117)	21.65 (550)	65 (30)
CRI 1s-7	1/2	1	●	14.92 (379)	6.19 (158)	5.18 (132)	24.21 (615)	71 (33)
CRI 1s-7		3	●	14.92 (379)	5.55 (141)	4.57 (117)	22.36 (568)	65 (30)
CRI 1s-8	1/2	1	●	15.63 (398)	6.19 (158)	5.18 (132)	24.92 (633)	72 (33)
CRI 1s-8		3	●	15.63 (398)	5.55 (141)	4.57 (117)	23.07 (586)	66 (30)
CRI 1s-9	3/4	1	●	16.34 (416)	6.19 (158)	5.18 (132)	26.25 (667)	77 (35)
CRI 1s-9		3	●	16.34 (416)	5.55 (141)	4.57 (117)	23.78 (605)	68 (31)
CRI 1s-10	3/4	1	●	17.05 (434)	6.19 (158)	5.18 (132)	26.96 (685)	78 (36)
CRI 1s-10		3	●	17.05 (434)	5.55 (141)	4.57 (117)	24.49 (623)	69 (32)
CRI 1s-11	3/4	1	●	17.76 (452)	6.19 (158)	5.18 (132)	27.67 (703)	79 (36)
CRI 1s-11		3	●	17.76 (452)	5.55 (141)	4.57 (117)	25.20 (641)	70 (32)
CRI 1s-12	3/4	1	●	18.46 (469)	6.19 (158)	5.18 (132)	28.37 (721)	79 (36)
CRI 1s-12		3	●	18.46 (469)	5.55 (141)	4.57 (117)	25.90 (658)	70 (32)
CRI 1s-13	1	1	●	19.17 (487)	7.19 (183)	5.73 (146)	30.36 (772)	96 (44)
CRI 1s-13		3	●	19.17 (487)	5.55 (141)	4.57 (117)	26.61 (676)	71 (33)
CRI 1s-15	1	1	●	20.59 (523)	7.19 (183)	5.73 (146)	31.78 (808)	97 (44)
CRI 1s-15		3	●	20.59 (523)	5.55 (141)	4.57 (117)	28.03 (712)	73 (34)
CRI 1s-17	1 1/2	1	●	22.01 (560)	7.19 (183)	5.73 (146)	33.69 (856)	102 (47)
CRI 1s-17		3	●	22.01 (560)	5.55 (141)	4.57 (117)	30.63 (779)	79 (36)
CRI 1s-19	1 1/2	1	-	23.43 (596)	7.19 (183)	5.73 (146)	35.11 (892)	104 (48)
CRI 1s-19		3	-	23.43 (596)	5.55 (141)	4.57 (117)	32.05 (815)	81 (37)
CRI 1s-21	1 1/2	1	-	24.84 (631)	7.19 (183)	5.73 (146)	36.52 (928)	106 (49)
CRI 1s-21		3	-	24.84 (631)	5.55 (141)	4.57 (117)	33.46 (850)	82 (38)
CRI 1s-23	1 1/2	1	-	26.26 (668)	7.19 (183)	5.73 (146)	37.94 (964)	107 (49)
CRI 1s-23		3	-	26.26 (668)	5.55 (141)	4.57 (117)	34.88 (886)	84 (39)
CRI 1s-25	2	1	-	27.68 (704)	7.19 (183)	5.73 (146)	40.24 (1023)	120 (55)
CRI 1s-25		3	-	27.68 (704)	7.01 (179)	4.33 (110)	38.90 (989)	111 (51)
CRI 1s-27	2	1	-	29.09 (739)	7.19 (183)	5.73 (146)	41.65 (1058)	122 (56)
CRI 1s-27		3	-	29.09 (739)	7.01 (179)	4.33 (110)	40.31 (1024)	113 (52)

All dimensions in inches unless otherwise noted.

* Oval flanged pump B1 and B1+B2 dimension is one inch less than ANSI flanged pump and weight is approximately 9 lbs. less.

- Available.

CRN 1s

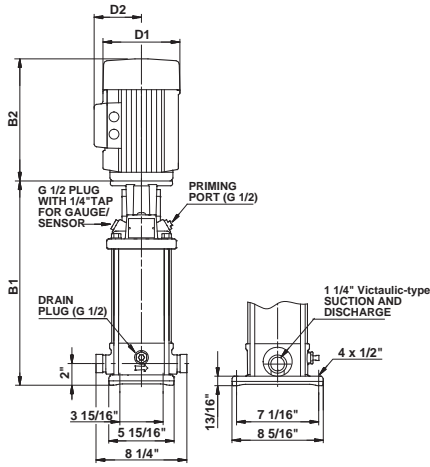

TM03 1454 2205

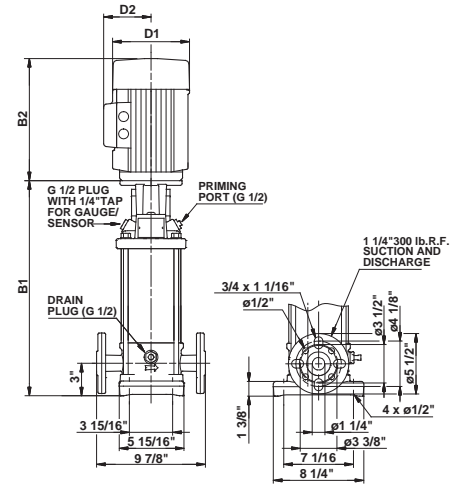

TM03 1453 2205

Pump type	P2 [Hp]	Ph.	PJE*	ANSI dimensions [inch (mm)]				Ship. wt. [lbs (kg)]
				B1	TEFC			
					D1	D2	B1+B2	
CRN 1s-2	1/3	1	•	12.09 (308)	6.19 (158)	5.18 (132)	21.38 (544)	63 (29)
		3	•	12.09 (308)	5.55 (141)	4.57 (117)	19.53 (497)	61 (28)
CRN 1s-3	1/3	1	•	12.09 (308)	6.19 (158)	5.18 (132)	21.38 (544)	64 (30)
		3	•	12.09 (308)	5.55 (141)	4.57 (117)	19.53 (497)	62 (29)
CRN 1s-4	1/3	1	•	12.80 (326)	6.19 (158)	5.18 (132)	22.09 (562)	65 (30)
		3	•	12.80 (326)	5.55 (141)	4.57 (117)	20.24 (515)	63 (29)
CRN 1s-5	1/3	1	•	13.50 (343)	6.19 (158)	5.18 (132)	22.79 (579)	66 (30)
		3	•	13.50 (343)	5.55 (141)	4.57 (117)	20.94 (532)	64 (30)
CRN 1s-6	1/2	1	•	14.21 (361)	6.19 (158)	5.18 (132)	23.50 (597)	70 (32)
		3	•	14.21 (361)	5.55 (141)	4.57 (117)	21.65 (550)	65 (30)
CRN 1s-7	1/2	1	•	14.92 (379)	6.19 (158)	5.18 (132)	24.21 (615)	71 (33)
		3	•	14.92 (379)	5.55 (141)	4.57 (117)	22.36 (568)	65 (30)
CRN 1s-8	1/2	1	•	15.63 (398)	6.19 (158)	5.18 (132)	24.92 (633)	72 (33)
		3	•	15.63 (398)	5.55 (141)	4.57 (117)	23.07 (586)	66 (30)
CRN 1s-9	3/4	1	•	16.34 (416)	6.19 (158)	5.18 (132)	26.25 (667)	77 (35)
		3	•	16.34 (416)	5.55 (141)	4.57 (117)	23.78 (605)	68 (31)
CRN 1s-10	3/4	1	•	17.05 (434)	6.19 (158)	5.18 (132)	26.96 (685)	78 (36)
		3	•	17.05 (434)	5.55 (141)	4.57 (117)	24.49 (623)	69 (32)
CRN 1s-11	3/4	1	•	17.76 (452)	6.19 (158)	5.18 (132)	27.67 (703)	78 (36)
		3	•	17.76 (452)	5.55 (141)	4.57 (117)	25.20 (641)	69 (32)
CRN 1s-12	3/4	1	•	18.46 (469)	6.19 (158)	5.18 (132)	28.37 (721)	79 (36)
		3	•	18.46 (469)	5.55 (141)	4.57 (117)	25.90 (658)	70 (32)
CRN 1s-13	1	1	•	19.17 (487)	7.19 (183)	5.73 (146)	30.36 (772)	96 (44)
		3	•	19.17 (487)	5.55 (141)	4.57 (117)	26.61 (676)	71 (33)
CRN 1s-15	1	1	•	20.59 (523)	7.19 (183)	5.73 (146)	31.78 (808)	97 (44)
		3	•	20.59 (523)	5.55 (141)	4.57 (117)	28.03 (712)	73 (34)
CRN 1s-17	1 1/2	1	•	22.01 (560)	7.19 (183)	5.73 (146)	33.69 (856)	102 (47)
		3	•	22.01 (560)	5.55 (141)	4.57 (117)	30.63 (779)	79 (36)
CRN 1s-19	1 1/2	1	•	23.43 (596)	7.19 (183)	5.73 (146)	35.11 (892)	104 (48)
		3	•	23.43 (596)	5.55 (141)	4.57 (117)	32.05 (815)	81 (37)
CRN 1s-21	1 1/2	1	•	24.84 (631)	7.19 (183)	5.73 (146)	36.52 (928)	105 (48)
		3	•	24.84 (631)	5.55 (141)	4.57 (117)	33.46 (850)	82 (38)
CRN 1s-23	1 1/2	1	•	26.26 (668)	7.19 (183)	5.73 (146)	37.94 (964)	107 (49)
		3	•	26.26 (668)	5.55 (141)	4.57 (117)	34.88 (886)	84 (39)
CRN 1s-25	2	1	•	27.68 (704)	7.19 (183)	5.73 (146)	40.24 (1023)	120 (55)
		3	•	27.68 (704)	7.01 (179)	4.33 (110)	38.90 (989)	111 (51)
CRN 1s-27	2	1	•	29.09 (739)	7.19 (183)	5.73 (146)	41.65 (1058)	122 (56)
		3	•	29.09 (739)	7.01 (179)	4.33 (110)	40.31 (1024)	112 (51)

All dimensions in inches unless otherwise noted.

* PJE flanged pump B1 and B1+B2 dimension is one inch less than ANSI flanged pump and weight is approximately 9 lbs. less.

• Available.

CR 1

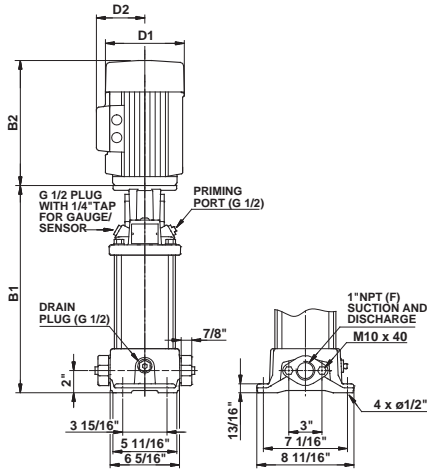

TM03 1450 2205

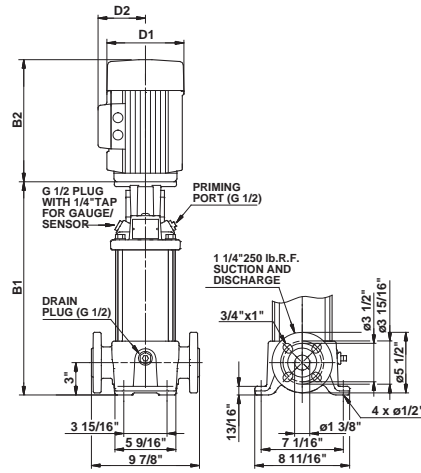

TM03 1451 2205

Pump type	P2 [Hp]	Ph.	Oval*	ANSI dimensions [inch (mm)]				Ship. wt. [lbs (kg)]
				B1	TEFC		B1+B2	
					D1	D2		
CR 1-2	1/3	1	●	11.97 (305)	6.19 (158)	5.18 (132)	21.26 (541)	69 (32)
		3	●	11.97 (305)	5.55 (141)	4.57 (117)	19.41 (494)	67 (31)
CR 1-3	1/3	1	●	11.97 (305)	6.19 (158)	5.18 (132)	21.26 (541)	69 (32)
		3	●	11.97 (305)	5.55 (141)	4.57 (117)	19.41 (494)	67 (31)
CR 1-4	1/2	1	●	12.68 (323)	6.19 (158)	5.18 (132)	21.97 (559)	73 (34)
		3	●	12.68 (323)	5.55 (141)	4.57 (117)	20.12 (512)	68 (31)
CR 1-5	1/2	1	●	13.39 (341)	6.19 (158)	5.18 (132)	22.68 (577)	75 (35)
		3	●	13.39 (341)	5.55 (141)	4.57 (117)	20.83 (530)	69 (32)
CR 1-6	3/4	1	●	14.09 (358)	6.19 (158)	5.18 (132)	24.00 (610)	80 (37)
		3	●	14.09 (358)	5.55 (141)	4.57 (117)	21.53 (547)	71 (33)
CR 1-7	3/4	1	●	14.80 (376)	6.19 (158)	5.18 (132)	24.71 (628)	81 (37)
		3	●	14.80 (376)	5.55 (141)	4.57 (117)	22.24 (565)	72 (33)
CR 1-8	1	1	●	15.51 (394)	7.19 (183)	5.73 (146)	26.70 (679)	93 (43)
		3	●	15.51 (394)	5.55 (141)	4.57 (117)	22.95 (583)	72 (33)
CR 1-9	1	1	●	16.22 (412)	7.19 (183)	5.73 (146)	27.41 (697)	94 (43)
		3	●	16.22 (412)	5.55 (141)	4.57 (117)	23.66 (601)	74 (34)
CR 1-10	1 1/2	1	●	16.93 (431)	7.19 (183)	5.73 (146)	28.61 (727)	95 (44)
		3	●	16.93 (431)	5.55 (141)	4.57 (117)	25.55 (649)	74 (34)
CR 1-11	1 1/2	1	●	17.64 (449)	7.19 (183)	5.73 (146)	29.32 (745)	102 (47)
		3	●	17.64 (449)	5.55 (141)	4.57 (117)	26.26 (668)	76 (35)
CR 1-12	1 1/2	1	●	18.35 (467)	7.19 (183)	5.73 (146)	30.03 (763)	103 (47)
		3	●	18.35 (467)	5.55 (141)	4.57 (117)	26.97 (686)	77 (35)
CR 1-13	1 1/2	1	●	19.06 (485)	7.19 (183)	5.73 (146)	30.74 (781)	104 (48)
		3	●	19.06 (485)	5.55 (141)	4.57 (117)	27.68 (704)	78 (36)
CR 1-15	2	1	●	20.47 (520)	7.19 (183)	5.73 (146)	33.03 (839)	114 (52)
		3	●	20.47 (520)	7.01 (179)	4.33 (110)	31.69 (805)	104 (48)
CR 1-17	2	1	●	21.89 (557)	7.19 (183)	5.73 (146)	34.45 (876)	116 (53)
		3	●	21.89 (557)	7.01 (179)	4.33 (110)	33.11 (841)	106 (49)
CR 1-19	3	1	-	24.41 (621)	8.60 (219)	6.87 (175)	39.06 (993)	155 (71)
		3	-	24.41 (621)	7.01 (179)	4.33 (110)	37.64 (957)	123 (56)
CR 1-21	3	1	-	25.83 (657)	8.60 (219)	6.87 (175)	40.48 (1029)	158 (72)
		3	-	25.83 (657)	7.01 (179)	4.33 (110)	39.06 (993)	125 (57)
CR 1-23	3	1	-	27.24 (692)	8.60 (219)	6.87 (175)	41.89 (1065)	159 (73)
		3	-	27.24 (692)	7.01 (179)	4.33 (110)	40.47 (1028)	130 (59)
CR 1-25	3	1	-	28.66 (728)	8.60 (219)	6.87 (175)	43.31 (1101)	161 (74)
		3	-	28.66 (728)	7.01 (179)	4.33 (110)	41.89 (1065)	132 (60)
CR 1-27	3	1	-	30.08 (765)	8.60 (219)	6.87 (175)	44.73 (1137)	163 (74)
		3	-	30.08 (765)	7.01 (179)	4.33 (110)	43.31 (1101)	134 (61)

All dimensions in inches unless otherwise noted.

* Oval flanged pump B1 and B1+B2 dimension is one inch less than ANSI flanged pump and weight is approximately 9 lbs. less.

- Available.

CRI 1

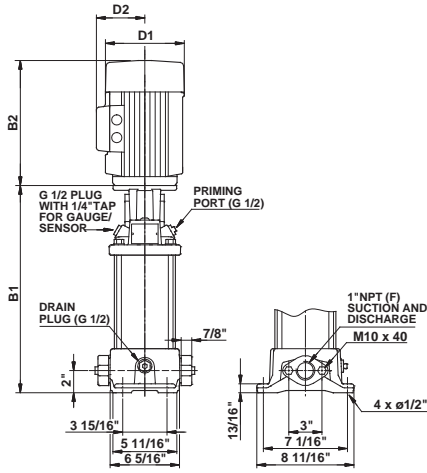

TM03 1450 2205

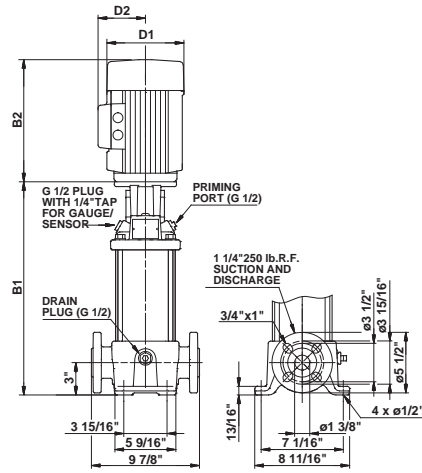

TM03 1451 2205

Pump type	P2 [Hp]	Ph.	Oval*	ANSI dimensions [inch (mm)]				Ship. wt. [lbs (kg)]
				B1	TEFC		B1+B2	
					D1	D2		
CRI 1-2	1/3	1	●	12.09 (308)	6.19 (158)	5.18 (132)	21.38 (544)	64 (30)
		3	●	12.09 (308)	5.55 (141)	4.57 (117)	19.53 (497)	62 (29)
CRI 1-3	1/3	1	●	12.09 (308)	6.19 (158)	5.18 (132)	21.38 (544)	64 (30)
		3	●	12.09 (308)	5.55 (141)	4.57 (117)	19.53 (497)	62 (29)
CRI 1-4	1/2	1	●	12.80 (326)	6.19 (158)	5.18 (132)	22.09 (562)	68 (31)
		3	●	12.80 (326)	5.55 (141)	4.57 (117)	20.24 (515)	63 (29)
CRI 1-5	1/2	1	●	13.50 (343)	6.19 (158)	5.18 (132)	22.79 (579)	69 (32)
		3	●	13.50 (343)	5.55 (141)	4.57 (117)	20.94 (532)	64 (30)
CRI 1-6	3/4	1	●	14.21 (361)	6.19 (158)	5.18 (132)	24.12 (613)	74 (34)
		3	●	14.21 (361)	5.55 (141)	4.57 (117)	21.65 (550)	65 (30)
CRI 1-7	3/4	1	●	14.92 (379)	6.19 (158)	5.18 (132)	24.83 (631)	75 (35)
		3	●	14.92 (379)	5.55 (141)	4.57 (117)	22.36 (568)	66 (66)
CRI 1-8	1	1	●	15.63 (398)	7.19 (183)	5.73 (146)	26.82 (682)	88 (40)
		3	●	15.63 (398)	5.55 (141)	4.57 (117)	23.07 (586)	67 (31)
CRI 1-9	1	1	●	16.34 (416)	7.19 (183)	5.73 (146)	27.53 (700)	89 (41)
		3	●	16.34 (416)	5.55 (141)	4.57 (117)	23.78 (605)	68 (31)
CRI 1-10	1 1/2	1	●	17.05 (434)	7.19 (183)	5.73 (146)	28.73 (730)	90 (41)
		3	●	17.05 (434)	5.55 (141)	4.57 (117)	25.67 (653)	69 (32)
CRI 1-11	1 1/2	1	●	17.76 (452)	7.19 (183)	5.73 (146)	29.44 (748)	97 (44)
		3	●	17.76 (452)	5.55 (141)	4.57 (117)	26.38 (671)	70 (32)
CRI 1-12	1 1/2	1	●	18.46 (469)	7.19 (183)	5.73 (146)	30.14 (766)	98 (45)
		3	●	18.46 (469)	5.55 (141)	4.57 (117)	27.08 (688)	71 (33)
CRI 1-13	1 1/2	1	●	19.17 (487)	7.19 (183)	5.73 (146)	30.85 (784)	99 (45)
		3	●	19.17 (487)	5.55 (141)	4.57 (117)	27.79 (706)	72 (33)
CRI 1-15	2	1	●	20.59 (523)	7.19 (183)	5.73 (146)	33.15 (843)	109 (50)
		3	●	20.59 (523)	7.01 (179)	4.33 (110)	31.81 (808)	99 (45)
CRI 1-17	2	1	●	22.01 (560)	7.19 (183)	5.73 (146)	34.57 (879)	110 (50)
		3	●	22.01 (560)	7.01 (179)	4.33 (110)	33.23 (845)	101 (46)
CRI 1-19	3	1	-	24.53 (624)	8.60 (219)	6.87 (175)	39.18 (996)	148 (68)
		3	-	24.53 (624)	7.01 (179)	4.33 (110)	37.76 (960)	116 (53)
CRI 1-21	3	1	-	25.94 (659)	8.60 (219)	6.87 (175)	40.59 (1031)	150 (69)
		3	-	25.94 (659)	7.01 (179)	4.33 (110)	39.17 (995)	118 (54)
CRI 1-23	3	1	-	27.36 (695)	8.60 (219)	6.87 (175)	42.01 (1068)	152 (69)
		3	-	27.36 (695)	7.01 (179)	4.33 (110)	40.59 (1031)	123 (56)
CRI 1-25	3	1	-	28.78 (732)	8.60 (219)	6.87 (175)	43.43 (1104)	154 (70)
		3	-	28.78 (732)	7.01 (179)	4.33 (110)	42.01 (1068)	125 (57)
CRI 1-27	3	1	-	30.20 (768)	8.60 (219)	6.87 (175)	44.85 (1140)	156 (71)
		3	-	30.20 (768)	7.01 (179)	4.33 (110)	43.43 (1104)	127 (58)

All dimensions in inches unless otherwise noted.

* Oval flanged pump B1 and B1+B2 dimension is one inch less than ANSI flanged pump and weight is approximately 9 lbs. less.

- Available.

CRN 1

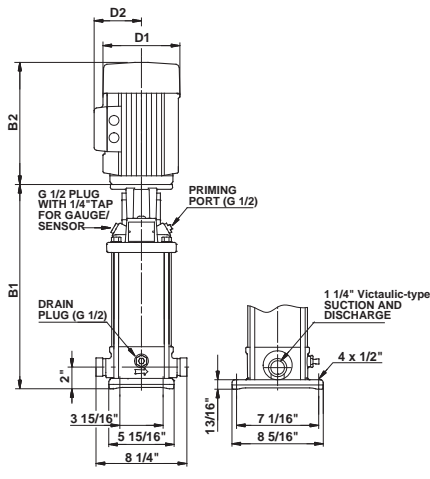

TM03 1454 2205

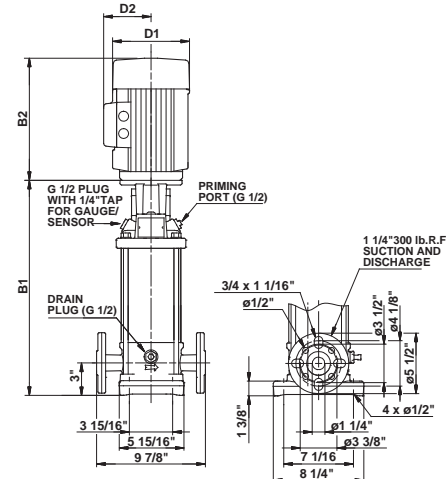

TM03 1453 2205

Pump type	P2 [Hp]	Ph.	PJE*	ANSI dimensions [inch (mm)]				Ship. wt. [lbs (kg)]
				B1	TEFC			
					D1	D2	B1+B2	
CRN 1-2	1/3	1	●	12.09 (308)	6.19 (158)	5.18 (132)	21.38 (544)	64 (30)
		3	●	12.09 (308)	5.55 (141)	4.57 (117)	19.53 (497)	62 (29)
CRN 1-3	1/3	1	●	12.09 (308)	6.19 (158)	5.18 (132)	21.38 (544)	64 (30)
		3	●	12.09 (308)	5.55 (141)	4.57 (117)	19.53 (497)	62 (29)
CRN 1-4	1/2	1	●	12.80 (326)	6.19 (158)	5.18 (132)	22.09 (562)	68 (31)
		3	●	12.80 (326)	5.55 (141)	4.57 (117)	20.24 (515)	63 (29)
CRN 1-5	1/2	1	●	13.50 (343)	6.19 (158)	5.18 (132)	22.79 (579)	69 (32)
		3	●	13.50 (343)	5.55 (141)	4.57 (117)	20.94 (532)	64 (30)
CRN 1-6	3/4	1	●	14.21 (361)	6.19 (158)	5.18 (132)	24.12 (613)	74 (34)
		3	●	14.21 (361)	5.55 (141)	4.57 (117)	21.65 (550)	65 (30)
CRN 1-7	3/4	1	●	14.92 (379)	6.19 (158)	5.18 (132)	24.83 (631)	75 (35)
		3	●	14.92 (379)	5.55 (141)	4.57 (117)	22.36 (568)	66 (30)
CRN 1-8	1	1	●	15.63 (398)	7.19 (183)	5.73 (146)	26.82 (682)	88 (40)
		3	●	15.63 (398)	5.55 (141)	4.57 (117)	23.07 (586)	67 (31)
CRN 1-9	1	1	●	16.34 (416)	7.19 (183)	5.73 (146)	27.53 (700)	89 (41)
		3	●	16.34 (416)	5.55 (141)	4.57 (117)	23.78 (605)	68 (31)
CRN 1-10	1 1/2	1	●	17.05 (434)	7.19 (183)	5.73 (146)	28.73 (730)	90 (41)
		3	●	17.05 (434)	5.55 (141)	4.57 (117)	25.67 (653)	69 (32)
CRN 1-11	1 1/2	1	●	17.76 (452)	7.19 (183)	5.73 (146)	29.44 (748)	97 (44)
		3	●	17.76 (452)	5.55 (141)	4.57 (117)	26.38 (671)	70 (32)
CRN 1-12	1 1/2	1	●	18.46 (469)	7.19 (183)	5.73 (146)	30.14 (766)	98 (45)
		3	●	18.46 (469)	5.55 (141)	4.57 (117)	27.08 (688)	71 (33)
CRN 1-13	1 1/2	1	●	19.17 (487)	7.19 (183)	5.73 (146)	30.85 (784)	99 (45)
		3	●	19.17 (487)	5.55 (141)	4.57 (117)	27.79 (706)	72 (33)
CRN 1-15	2	1	●	20.59 (523)	7.19 (183)	5.73 (146)	33.15 (843)	108 (49)
		3	●	20.59 (523)	7.01 (179)	4.33 (110)	31.81 (808)	99 (45)
CRN 1-17	2	1	●	22.01 (560)	7.19 (183)	5.73 (146)	34.57 (879)	110 (50)
		3	●	22.01 (560)	7.01 (179)	4.33 (110)	33.23 (845)	101 (46)
CRN 1-19	3	1	●	23.53 (598)	8.60 (219)	6.87 (175)	39.18 (996)	148 (68)
		3	●	23.53 (598)	7.01 (179)	4.33 (110)	37.76 (960)	116 (53)
CRN 1-21	3	1	●	25.94 (659)	8.60 (219)	6.87 (175)	40.59 (1031)	150 (69)
		3	●	25.94 (659)	7.01 (179)	4.33 (110)	39.17 (995)	118 (54)
CRN 1-23	3	1	●	27.36 (695)	8.60 (219)	6.87 (175)	42.01 (1068)	152 (69)
		3	●	27.36 (695)	7.01 (179)	4.33 (110)	40.59 (1031)	123 (56)
CRN 1-25	3	1	●	28.78 (732)	8.60 (219)	6.87 (175)	43.43 (1104)	154 (70)
		3	●	28.78 (732)	7.01 (179)	4.33 (110)	42.01 (1068)	124 (57)
CRN 1-27	3	1	●	30.20 (768)	8.60 (219)	6.87 (175)	44.85 (1140)	155 (71)
		3	●	30.20 (768)	7.01 (179)	4.33 (110)	43.43 (1104)	126 (58)

All dimensions in inches unless otherwise noted.

* PJE flanged pump B1 and B1+B2 dimension is one inch less than ANSI flanged pump and weight is approximately 9 lbs. less.

● Available.

CR 3

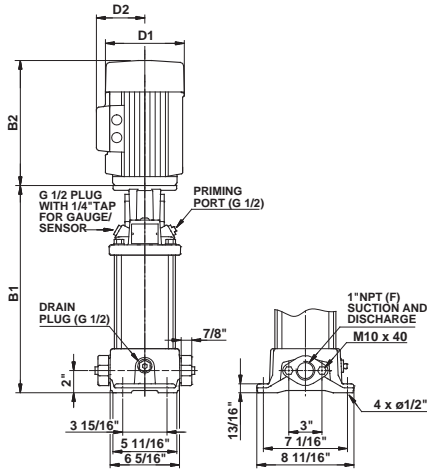

TM03 1450 2205

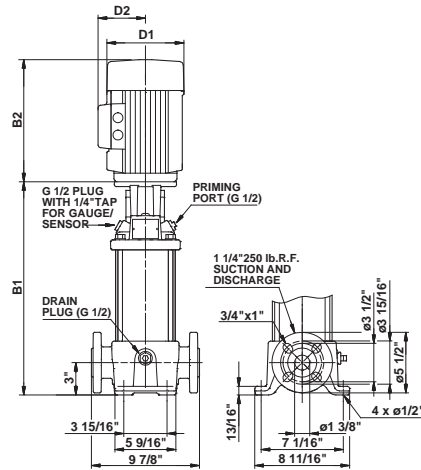

TM03 1451 2205

Pump type	P2 [Hp]	Ph.	Oval*	ANSI dimensions [inch (mm)]				Ship. wt. [lbs (kg)]
				B1	TEFC			
					D1	D2	B1+B2	
CR 3-2	1/3	1	●	11.97 (305)	6.19 (158)	5.18 (132)	21.26 (541)	69 (32)
		3	●	11.97 (305)	5.55 (141)	4.57 (117)	19.41 (494)	67 (31)
CR 3-3	1/2	1	●	11.97 (305)	6.19 (158)	5.18 (132)	21.26 (541)	73 (34)
		3	●	11.97 (305)	5.55 (141)	4.57 (117)	19.41 (494)	67 (31)
CR 3-4	3/4	1	●	12.68 (323)	6.19 (158)	5.18 (132)	22.59 (574)	78 (36)
		3	●	12.68 (323)	5.55 (141)	4.57 (117)	20.12 (512)	69 (32)
CR 3-5	3/4	1	●	13.39 (341)	6.19 (158)	5.18 (132)	23.30 (592)	79 (36)
		3	●	13.39 (341)	5.55 (141)	4.57 (117)	20.83 (530)	70 (32)
CR 3-6	1	1	●	14.09 (358)	7.19 (183)	5.73 (146)	25.28 (643)	91 (42)
		3	●	14.09 (358)	5.55 (141)	4.57 (117)	21.53 (547)	71 (33)
CR 3-7	1 1/2	1	●	14.80 (376)	7.19 (183)	5.73 (146)	26.48 (673)	95 (44)
		3	●	14.80 (376)	5.55 (141)	4.57 (117)	23.42 (595)	72 (33)
CR 3-8	1 1/2	1	●	15.51 (394)	7.19 (183)	5.73 (146)	27.19 (691)	96 (44)
		3	●	15.51 (394)	5.55 (141)	4.57 (117)	24.13 (613)	73 (34)
CR 3-9	1 1/2	1	●	16.22 (412)	7.19 (183)	5.73 (146)	27.90 (709)	97 (44)
		3	●	16.22 (412)	5.55 (141)	4.57 (117)	24.84 (631)	74 (34)
CR 3-10	2	1	●	16.93 (431)	7.19 (183)	5.73 (146)	29.49 (750)	109 (50)
		3	●	16.93 (431)	7.01 (179)	4.33 (110)	28.15 (716)	96 (44)
CR 3-11	2	1	●	17.64 (449)	7.19 (183)	5.73 (146)	30.20 (768)	110 (50)
		3	●	17.64 (449)	7.01 (179)	4.33 (110)	28.86 (734)	101 (46)
CR 3-12	2	1	●	18.35 (467)	7.19 (183)	5.73 (146)	30.91 (786)	111 (51)
		3	●	18.35 (467)	7.01 (179)	4.33 (110)	29.57 (752)	102 (47)
CR 3-13	3	1	●	20.16 (513)	8.60 (219)	6.87 (175)	34.81 (885)	147 (67)
		3	●	20.16 (513)	7.01 (179)	4.33 (110)	33.39 (849)	118 (54)
CR 3-15	3	1	●	21.57 (548)	8.60 (219)	6.87 (175)	36.22 (920)	149 (68)
		3	●	21.57 (548)	7.01 (179)	4.33 (110)	34.80 (884)	120 (55)
CR 3-17	3	1	●	22.99 (584)	8.60 (219)	6.87 (175)	37.64 (957)	150 (69)
		3	●	22.99 (584)	7.01 (179)	4.33 (110)	36.22 (920)	121 (55)
CR 3-19	5	1	-	24.41 (621)	10.62 (270)	7.46 (190)	39.93 (1015)	179 (82)
		3	-	24.41 (621)	8.66 (220)	5.28 (135)	39.92 (1014)	175 (80)
CR 3-21	5	1	-	25.83 (657)	10.62 (270)	7.46 (190)	41.35 (1051)	181 (83)
		3	-	25.83 (657)	8.66 (220)	5.28 (135)	41.34 (1051)	177 (81)
CR 3-23	5	1	-	27.24 (692)	10.62 (270)	7.46 (190)	42.76 (1087)	182 (83)
		3	-	27.24 (692)	8.66 (220)	5.28 (135)	42.75 (1086)	179 (82)
CR 3-25	5	1	-	28.66 (728)	10.62 (270)	7.46 (190)	44.18 (1123)	184 (84)
		3	-	28.66 (728)	8.66 (220)	5.28 (135)	44.17 (1122)	181 (83)

All dimensions in inches unless otherwise noted.

* Oval flanged pump B1 and B1+B2 dimension is one inch less than ANSI flanged pump and weight is approximately 9 lbs. less.

- Available.

CRI 3

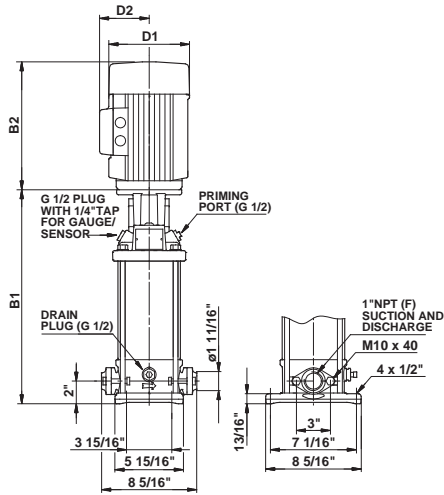

TM03 1452 2205

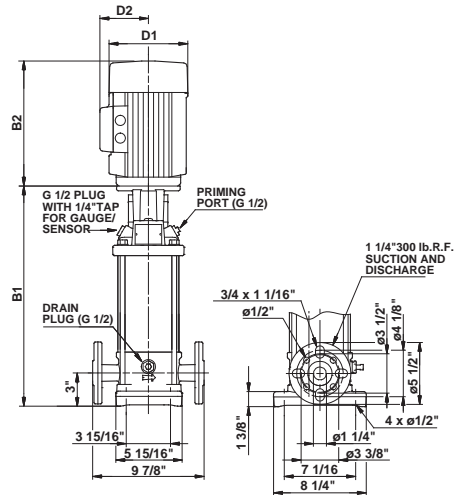

TM03 1453 2205

Pump type	P2 [Hp]	Ph.	Oval*	ANSI dimensions [inch (mm)]				Ship. wt. [lbs (kg)]
				B1	TEFC			
					D1	D2	B1+B2	
CRI 3-2	1/3	1	●	12.09 (308)	6.19 (158)	5.18 (132)	21.38 (544)	64 (30)
		3	●	12.09 (308)	5.55 (141)	4.57 (117)	19.53 (497)	62 (29)
CRI 3-3	1/2	1	●	12.09 (308)	6.19 (158)	5.18 (132)	21.38 (544)	67 (31)
		3	●	12.09 (308)	5.55 (141)	4.57 (117)	19.53 (497)	62 (29)
CRI 3-4	3/4	1	●	12.80 (326)	6.19 (158)	5.18 (132)	22.71 (577)	73 (34)
		3	●	12.80 (326)	5.55 (141)	4.57 (117)	20.24 (515)	63 (29)
CRI 3-5	3/4	1	●	13.50 (343)	6.19 (158)	5.18 (132)	23.41 (595)	74 (34)
		3	●	13.50 (343)	5.55 (141)	4.57 (117)	20.94 (532)	65 (30)
CRI 3-6	1	1	●	14.21 (361)	7.19 (183)	5.73 (146)	25.40 (646)	86 (40)
		3	●	14.21 (361)	5.55 (141)	4.57 (117)	21.65 (550)	65 (30)
CRI 3-7	1 1/2	1	●	14.92 (379)	7.19 (183)	5.73 (146)	26.60 (676)	90 (41)
		3	●	14.92 (379)	5.55 (141)	4.57 (117)	23.54 (598)	67 (31)
CRI 3-8	1 1/2	1	●	15.63 (398)	7.19 (183)	5.73 (146)	27.31 (694)	91 (42)
		3	●	15.63 (398)	5.55 (141)	4.57 (117)	24.25 (616)	68 (31)
CRI 3-9	1 1/2	1	●	16.34 (416)	7.19 (183)	5.73 (146)	28.02 (712)	92 (42)
		3	●	16.34 (416)	5.55 (141)	4.57 (117)	24.96 (634)	69 (32)
CRI 3-10	2	1	●	17.05 (434)	7.19 (183)	5.73 (146)	29.61 (753)	104 (48)
		3	●	17.05 (434)	7.01 (179)	4.33 (110)	28.27 (719)	91 (42)
CRI 3-11	2	1	●	17.76 (452)	7.19 (183)	5.73 (146)	30.32 (771)	105 (48)
		3	●	17.76 (452)	7.01 (179)	4.33 (110)	28.98 (737)	95 (44)
CRI 3-12	2	1	●	18.46 (469)	7.19 (183)	5.73 (146)	31.02 (788)	106 (49)
		3	●	18.46 (469)	7.01 (179)	4.33 (110)	29.68 (754)	96 (44)
CRI 3-13	3	1	●	20.28 (516)	8.60 (219)	6.87 (175)	34.93 (888)	140 (64)
		3	●	20.28 (516)	7.01 (179)	4.33 (110)	33.51 (852)	111 (51)
CRI 3-15	3	1	●	21.69 (551)	8.60 (219)	6.87 (175)	36.34 (924)	142 (65)
		3	●	21.69 (551)	7.01 (179)	4.33 (110)	34.92 (887)	113 (52)
CRI 3-17	3	1	●	23.11 (587)	8.60 (219)	6.87 (175)	37.76 (960)	143 (65)
		3	●	23.11 (587)	7.01 (179)	4.33 (110)	36.34 (924)	114 (52)
CRI 3-19	5	1	-	24.53 (624)	10.62 (270)	7.46 (190)	40.05 (1018)	172 (79)
		3	-	24.53 (624)	8.66 (220)	5.28 (135)	40.04 (1018)	168 (77)
CRI 3-21	5	1	-	25.94 (659)	10.62 (270)	7.46 (190)	41.46 (1054)	174 (79)
		3	-	25.94 (659)	8.66 (220)	5.28 (135)	41.45 (1053)	170 (78)
CRI 3-23	5	1	-	27.36 (695)	10.62 (270)	7.46 (190)	42.88 (1090)	175 (80)
		3	-	27.36 (695)	8.66 (220)	5.28 (135)	42.87 (1089)	172 (79)
CRI 3-25	5	1	-	28.78 (732)	10.62 (270)	7.46 (190)	44.30 (1126)	177 (81)
		3	-	28.78 (732)	8.66 (220)	5.28 (135)	44.29 (1125)	174 (79)

All dimensions in inches unless otherwise noted.

* Oval flanged pump B1 and B1+B2 dimension is one inch less than ANSI flanged pump and weight is approximately 9 lbs. less.

- Available.

CRN 3

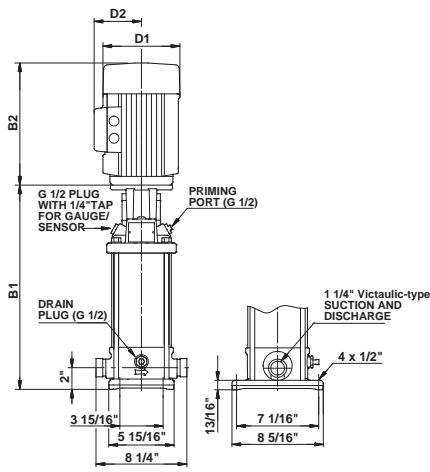

TM03 1454 2205

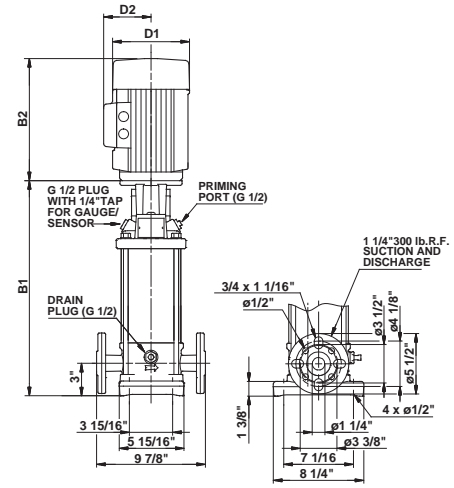

TM03 1453 2205

Pump type	P2 [Hp]	Ph.	PJE*	ANSI dimensions [inch (mm)]				Ship. wt. [lbs (kg)]
				B1	TEFC			
					D1	D2	B1+B2	
CRN 3-2	1/3	1	•	12.09 (308)	6.19 (158)	5.18 (132)	21.38 (544)	64 (30)
		3	•	12.09 (308)	5.55 (141)	4.57 (117)	19.53 (497)	62 (29)
CRN 3-3	1/2	1	•	12.09 (308)	6.19 (158)	5.18 (132)	21.38 (544)	67 (31)
		3	•	12.09 (308)	5.55 (141)	4.57 (117)	19.53 (497)	62 (29)
CRN 3-4	3/4	1	•	12.80 (326)	6.19 (158)	5.18 (132)	22.71 (577)	73 (34)
		3	•	12.80 (326)	5.55 (141)	4.57 (117)	20.24 (515)	63 (29)
CRN 3-5	3/4	1	•	13.50 (343)	6.19 (158)	5.18 (132)	23.41 (595)	73 (34)
		3	•	13.50 (343)	5.55 (141)	4.57 (117)	20.94 (532)	64 (30)
CRN 3-6	1	1	•	14.21 (361)	7.19 (183)	5.73 (146)	25.40 (646)	86 (40)
		3	•	14.21 (361)	5.55 (141)	4.57 (117)	21.65 (550)	65 (30)
CRN 3-7	1 1/2	1	•	14.92 (379)	7.19 (183)	5.73 (146)	26.60 (676)	90 (41)
		3	•	14.92 (379)	5.55 (141)	4.57 (117)	23.54 (598)	67 (31)
CRN 3-8	1 1/2	1	•	15.63 (398)	7.19 (183)	5.73 (146)	27.31 (694)	91 (42)
		3	•	15.63 (398)	5.55 (141)	4.57 (117)	24.25 (616)	68 (31)
CRN 3-9	1 1/2	1	•	16.34 (416)	7.19 (183)	5.73 (146)	28.02 (712)	92 (42)
		3	•	16.34 (416)	5.55 (141)	4.57 (117)	24.96 (634)	69 (32)
CRN 3-10	2	1	•	17.05 (434)	7.19 (183)	5.73 (146)	29.61 (753)	104 (48)
		3	•	17.05 (434)	7.01 (179)	4.33 (110)	28.27 (719)	91 (42)
CRN 3-11	2	1	•	17.76 (452)	7.19 (183)	5.73 (146)	30.32 (771)	105 (48)
		3	•	17.76 (452)	7.01 (179)	4.33 (110)	28.98 (737)	95 (44)
CRN 3-12	2	1	•	18.46 (469)	7.19 (183)	5.73 (146)	31.02 (788)	106 (49)
		3	•	18.46 (469)	7.01 (179)	4.33 (110)	29.68 (754)	96 (44)
CRN 3-13	3	1	•	20.28 (516)	8.60 (219)	6.87 (175)	34.93 (888)	139 (64)
		3	•	20.28 (516)	7.01 (179)	4.33 (110)	33.51 (852)	110 (50)
CRN 3-15	3	1	•	21.69 (551)	8.60 (219)	6.87 (175)	36.34 (924)	142 (65)
		3	•	21.69 (551)	7.01 (179)	4.33 (110)	34.92 (887)	112 (51)
CRN 3-17	3	1	•	23.11 (587)	8.60 (219)	6.87 (175)	37.76 (960)	143 (65)
		3	•	23.11 (587)	7.01 (179)	4.33 (110)	36.34 (924)	114 (52)
CRN 3-19	5	1	•	24.53 (624)	10.62 (270)	7.46 (190)	40.05 (1018)	172 (79)
		3	•	24.53 (624)	8.66 (220)	5.28 (135)	40.04 (1018)	168 (77)
CRN 3-21	5	1	•	25.94 (659)	10.62 (270)	7.46 (190)	41.46 (1054)	174 (79)
		3	•	25.94 (659)	8.66 (220)	5.28 (135)	41.45 (1053)	170 (78)
CRN 3-23	5	1	•	27.36 (695)	10.62 (270)	7.46 (190)	42.88 (1090)	175 (80)
		3	•	27.36 (695)	8.66 (220)	5.28 (135)	42.87 (1089)	171 (78)
CRN 3-25	5	1	•	28.78 (732)	10.62 (270)	7.46 (190)	44.30 (1126)	177 (81)
		3	•	28.78 (732)	8.66 (220)	5.28 (135)	44.29 (1125)	173 (79)

All dimensions in inches unless otherwise noted.

* PJE flanged pump B1 and B1+B2 dimension is one inch less than ANSI flanged pump and weight is approximately 9 lbs. less.

- Available.

CR 5

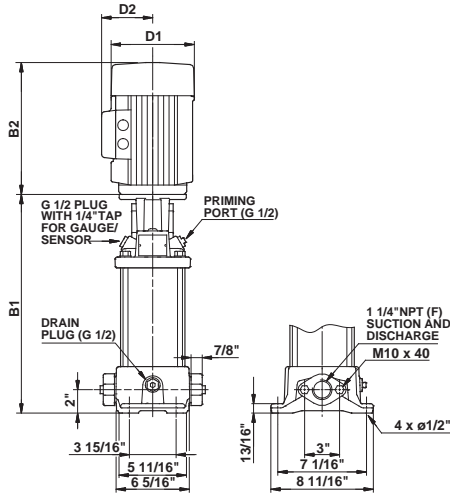

TM03 1455 2205

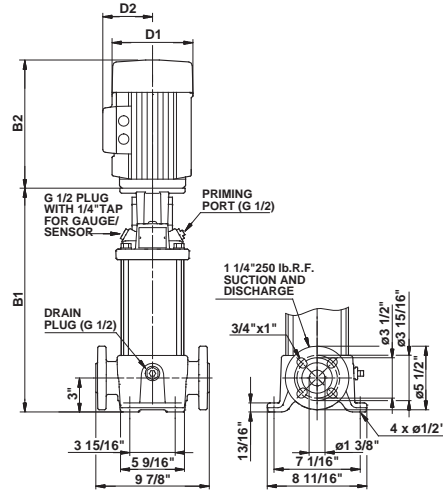

TM03 1451 2205

Pump type	P2 [Hp]	Ph.	Oval*	ANSI dimensions [inch (mm)]				Ship. wt. [lbs (kg)]
				B1	TEFC			
					D1	D2	B1+B2	
CR 5-2	3/4	1	•	11.97 (305)	6.19 (158)	5.18 (132)	21.88 (556)	77 (35)
		3	•	11.97 (305)	5.55 (141)	4.57 (117)	19.41 (494)	68 (31)
CR 5-3	1	1	•	13.03 (331)	7.19 (183)	5.73 (146)	24.22 (616)	90 (41)
		3	•	13.03 (331)	5.55 (141)	4.57 (117)	20.47 (520)	69 (32)
CR 5-4	1 1/2	1	•	14.09 (358)	7.19 (183)	5.73 (146)	25.77 (655)	94 (43)
		3	•	14.09 (358)	5.55 (141)	4.57 (117)	22.71 (577)	71 (33)
CR 5-5	2	1	•	15.16 (386)	7.19 (183)	5.73 (146)	27.72 (705)	106 (49)
		3	•	15.16 (386)	7.01 (179)	4.33 (110)	26.38 (671)	93 (43)
CR 5-6	2	1	•	16.22 (412)	7.19 (183)	5.73 (146)	28.78 (732)	108 (49)
		3	•	16.22 (412)	7.01 (179)	4.33 (110)	27.44 (697)	95 (44)
CR 5-7	3	1	•	18.39 (468)	8.60 (219)	6.87 (175)	33.04 (840)	143 (65)
		3	•	18.39 (468)	7.01 (179)	4.33 (110)	31.62 (804)	114 (52)
CR 5-8	3	1	•	19.45 (495)	8.60 (219)	6.87 (175)	34.10 (867)	145 (66)
		3	•	19.45 (495)	7.01 (179)	4.33 (110)	32.68 (831)	116 (53)
CR 5-9	3	1	•	20.51 (521)	8.60 (219)	6.87 (175)	35.16 (894)	147 (67)
		3	•	20.51 (521)	7.01 (179)	4.33 (110)	33.74 (857)	118 (54)
CR 5-10	5	1	•	21.57 (548)	10.62 (270)	7.46 (190)	37.09 (943)	170 (78)
		3	•	21.57 (548)	8.66 (220)	5.28 (135)	37.08 (942)	168 (77)
CR 5-11	5	1	•	22.64 (576)	10.62 (270)	7.46 (190)	38.16 (970)	172 (79)
		3	•	22.64 (576)	8.66 (220)	5.28 (135)	38.15 (970)	169 (77)
CR 5-12	5	1	•	23.7 (602)	10.62 (270)	7.46 (190)	39.22 (997)	177 (81)
		3	•	23.7 (602)	8.66 (220)	5.28 (135)	39.21 (996)	170 (78)
CR 5-13	5	1	•	24.76 (629)	10.62 (270)	7.46 (190)	40.28 (1024)	178 (81)
		3	•	24.76 (629)	8.66 (220)	5.28 (135)	40.27 (1023)	171 (78)
CR 5-14	5	1	•	25.83 (657)	10.62 (270)	7.46 (190)	41.35 (1051)	180 (82)
		3	•	25.83 (657)	8.66 (220)	5.28 (135)	41.34 (1051)	176 (80)
CR 5-15	5	1	•	26.89 (684)	10.62 (270)	7.46 (190)	42.41 (1078)	181 (83)
		3	•	26.89 (684)	8.66 (220)	5.28 (135)	42.40 (1077)	177 (81)
CR 5-16	5	1	•	27.95 (710)	10.62 (270)	7.46 (190)	43.47 (1105)	182 (83)
		3	•	27.95 (710)	8.66 (220)	5.28 (135)	43.46 (1104)	178 (81)
CR 5-18	7 1/2	1	-	30.59 (777)	10.22 (260)	7.62 (194)	46.12 (1172)	200 (91)
		3	-	30.59 (777)	8.66 (220)	5.28 (135)	46.19 (1171)	188 (86)
CR 5-20	7 1/2	1	-	32.72 (832)	10.22 (260)	7.62 (194)	48.25 (1226)	203 (93)
		3	-	32.72 (832)	8.66 (220)	5.28 (135)	48.23 (1226)	190 (87)
CR 5-22	7 1/2	1	-	34.84 (885)	10.22 (260)	7.62 (194)	50.37 (1280)	300 (137)
		3	-	34.84 (885)	8.66 (220)	5.28 (135)	50.35 (1279)	287 (131)
CR 5-24	7 1/2	1	-	36.97 (940)	10.22 (260)	7.62 (194)	52.50 (1334)	302 (137)
		3	-	36.97 (940)	8.66 (220)	5.28 (135)	52.48 (1333)	290 (132)

All dimensions in inches unless otherwise noted.

* Oval flanged pump B1 and B1+B2 dimension is one inch less than ANSI flanged pumps and weight is approximately 9 lbs. less.

• Available.

CRI 5

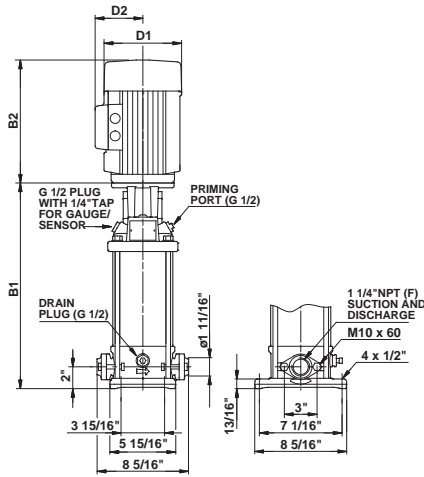

TMO3 1456 2205

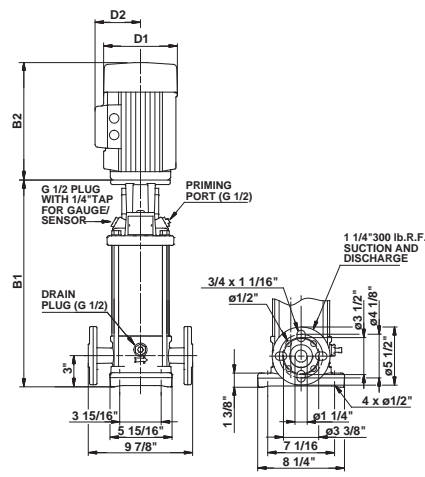

TMO3 1453 2205

Pump type	P2 [Hp]	Ph.	Oval*	ANSI dimensions [inch (mm)]				Ship. wt. [lbs (kg)]
				B1	TEFC			
					D1	D2	B1+B2	
CRI 5-2	3/4	1	•	12.09 (308)	6.19 (158)	5.18 (132)	22.00 (559)	71 (33)
		3	•	12.09 (308)	5.55 (141)	4.57 (117)	19.53 (497)	62 (29)
CRI 5-3	1	1	•	13.15 (335)	7.19 (183)	5.73 (146)	24.34 (619)	85 (39)
		3	•	13.15 (335)	5.55 (141)	4.57 (117)	20.59 (523)	64 (30)
CRI 5-4	1 1/2	1	•	14.21 (361)	7.19 (183)	5.73 (146)	25.89 (658)	89 (41)
		3	•	14.21 (361)	5.55 (141)	4.57 (117)	22.83 (580)	66 (30)
CRI 5-5	2	1	•	15.28 (389)	7.19 (183)	5.73 (146)	27.84 (708)	101 (46)
		3	•	15.28 (389)	7.01 (179)	4.33 (110)	26.50 (674)	88 (40)
CRI 5-6	2	1	•	16.34 (416)	7.19 (183)	5.73 (146)	28.90 (735)	103 (47)
		3	•	16.34 (416)	7.01 (179)	4.33 (110)	27.56 (701)	90 (41)
CRI 5-7	3	1	•	18.51 (471)	8.60 (219)	6.87 (175)	33.16 (843)	136 (62)
		3	•	18.51 (471)	7.01 (179)	4.33 (110)	31.74 (807)	107 (49)
CRI 5-8	3	1	•	19.57 (498)	8.60 (219)	6.87 (175)	34.22 (870)	138 (63)
		3	•	19.57 (498)	7.01 (179)	4.33 (110)	32.80 (834)	109 (50)
CRI 5-9	3	1	•	20.63 (525)	8.60 (219)	6.87 (175)	35.28 (897)	140 (64)
		3	•	20.63 (525)	7.01 (179)	4.33 (110)	33.86 (861)	111 (51)
CRI 5-10	5	1	•	21.69 (551)	10.62 (270)	7.46 (190)	37.21 (946)	163 (74)
		3	•	21.69 (551)	8.66 (220)	5.28 (135)	37.20 (945)	160 (73)
CRI 5-11	5	1	•	22.76 (579)	10.62 (270)	7.46 (190)	38.28 (973)	165 (75)
		3	•	22.76 (579)	8.66 (220)	5.28 (135)	38.27 (973)	162 (74)
CRI 5-12	5	1	•	23.82 (606)	10.62 (270)	7.46 (190)	39.34 (1000)	170 (78)
		3	•	23.82 (606)	8.66 (220)	5.28 (135)	39.33 (999)	163 (74)
CRI 5-13	5	1	•	24.88 (632)	10.62 (270)	7.46 (190)	40.40 (1027)	171 (78)
		3	•	24.88 (632)	8.66 (220)	5.28 (135)	40.39 (1026)	164 (75)
CRI 5-14	5	1	•	25.94 (659)	10.62 (270)	7.46 (190)	41.46 (1054)	173 (79)
		3	•	25.94 (659)	8.66 (220)	5.28 (135)	41.45 (1053)	169 (77)
CRI 5-15	5	1	•	27.01 (687)	10.62 (270)	7.46 (190)	42.53 (1081)	174 (79)
		3	•	27.01 (687)	8.66 (220)	5.28 (135)	42.52 (1081)	170 (78)
CRI 5-16	5	1	•	28.07 (713)	10.62 (270)	7.46 (190)	43.59 (1108)	175 (80)
		3	•	28.07 (713)	8.66 (220)	5.28 (135)	43.58 (1107)	171 (78)
CRI 5-18	7 1/2	1	-	30.71 (781)	10.22 (260)	7.62 (194)	46.24 (1175)	193 (88)
		3	-	30.71 (781)	8.66 (220)	5.28 (135)	46.22 (1174)	181 (83)
CRI 5-20	7 1/2	1	-	32.83 (834)	10.22 (260)	7.62 (194)	48.36 (1229)	196 (89)
		3	-	32.83 (834)	8.66 (220)	5.28 (135)	48.34 (1228)	183 (84)
CRI 5-22	7 1/2	1	-	34.96 (888)	10.22 (260)	7.62 (194)	50.49 (1283)	293 (133)
		3	-	34.96 (888)	8.66 (220)	5.28 (135)	50.47 (1282)	280 (128)
CRI 5-24	7 1/2	1	-	37.09 (943)	10.22 (260)	7.62 (194)	52.62 (1337)	295 (134)
		3	-	37.09 (943)	8.66 (220)	5.28 (135)	52.60 (1337)	283 (129)

All dimensions in inches unless otherwise noted.

* Oval flanged pump B1 and B1+B2 dimension is one inch less than ANSI flanged pumps and weight is approximately 9 lbs. less.

• Available.

CRN 5

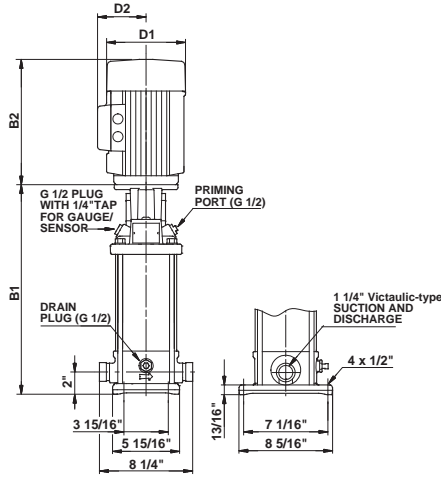

TM03 1454 2205

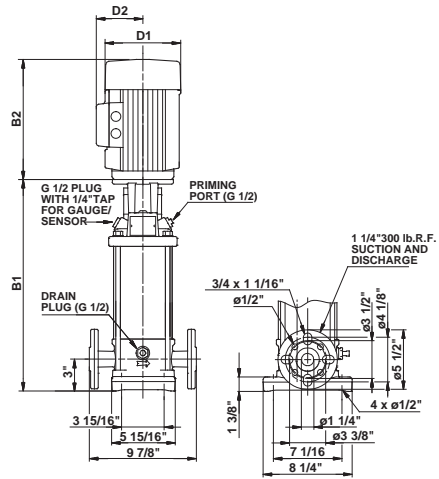

TM03 1453 2205

Pump type	P2 [Hp]	Ph.	PJE*	ANSI dimensions [inch (mm)]				Ship. wt. [lbs (kg)]
				B1	TEFC			
					D1	D2	B1+B2	
CRN 5-2	3/4	1	•	12.09 (308)	6.19 (158)	5.18 (132)	22.00 (559)	71 (33)
		3	•	12.09 (308)	5.55 (141)	4.57 (117)	19.53 (497)	62 (29)
CRN 5-3	1	1	•	13.15 (335)	7.19 (183)	5.73 (146)	24.34 (619)	85 (39)
		3	•	13.15 (335)	5.55 (141)	4.57 (117)	20.59 (523)	64 (30)
CRN 5-4	1 1/2	1	•	14.21 (361)	7.19 (183)	5.73 (146)	25.89 (658)	89 (41)
		3	•	14.21 (361)	5.55 (141)	4.57 (117)	22.83 (580)	65 (30)
CRN 5-5	2	1	•	15.28 (389)	7.19 (183)	5.73 (146)	27.84 (708)	101 (46)
		3	•	15.28 (389)	7.01 (179)	4.33 (110)	26.5 (674)	88 (40)
CRN 5-6	2	1	•	16.34 (416)	7.19 (183)	5.73 (146)	28.90 (735)	103 (47)
		3	•	16.34 (416)	7.01 (179)	4.33 (110)	27.56 (701)	90 (41)
CRN 5-7	3	1	•	18.51 (471)	8.60 (219)	6.87 (175)	33.16 (843)	136 (62)
		3	•	18.51 (471)	7.01 (179)	4.33 (110)	31.74 (807)	107 (49)
CRN 5-8	3	1	•	19.57 (498)	8.60 (219)	6.87 (175)	34.22 (870)	138 (63)
		3	•	19.57 (498)	7.01 (179)	4.33 (110)	32.80 (834)	109 (50)
CRN 5-9	3	1	•	20.63 (525)	8.60 (219)	6.87 (175)	35.28 (897)	139 (64)
		3	•	20.63 (525)	7.01 (179)	4.33 (110)	33.86 (861)	110 (50)
CRN 5-10	5	1	•	21.69 (551)	10.62 (270)	7.46 (190)	37.21 (946)	163 (74)
		3	•	21.69 (551)	8.66 (220)	5.28 (135)	37.20 (945)	160 (73)
CRN 5-11	5	1	•	22.76 (579)	10.62 (270)	7.46 (190)	38.28 (973)	165 (75)
		3	•	22.76 (579)	8.66 (220)	5.28 (135)	38.27 (973)	161 (74)
CRN 5-12	5	1	•	23.82 (606)	10.62 (270)	7.46 (190)	39.34 (1000)	170 (78)
		3	•	23.82 (606)	8.66 (220)	5.28 (135)	39.33 (999)	163 (74)
CRN 5-13	5	1	•	24.88 (632)	10.62 (270)	7.46 (190)	40.40 (1027)	171 (78)
		3	•	24.88 (632)	8.66 (220)	5.28 (135)	40.39 (1026)	164 (75)
CRN 5-14	5	1	•	25.94 (659)	10.62 (270)	7.46 (190)	41.46 (1054)	172 (79)
		3	•	25.94 (659)	8.66 (220)	5.28 (135)	41.45 (1053)	169 (77)
CRN 5-15	5	1	•	27.01 (687)	10.62 (270)	7.46 (190)	42.53 (1081)	173 (79)
		3	•	27.01 (687)	8.66 (220)	5.28 (135)	42.52 (1081)	170 (78)
CRN 5-16	5	1	•	28.07 (713)	10.62 (270)	7.46 (190)	43.59 (1108)	175 (80)
		3	•	28.07 (713)	8.66 (220)	5.28 (135)	43.58 (1107)	171 (78)
CRN 5-18	7 1/2	1	•	30.71 (781)	10.22 (260)	7.62 (194)	46.24 (1175)	193 (88)
		3	•	30.71 (781)	8.66 (220)	5.28 (135)	46.22 (1174)	180 (82)
CRN 5-20	7 1/2	1	•	32.83 (834)	10.22 (260)	7.62 (194)	48.36 (1229)	196 (89)
		3	•	32.83 (834)	8.66 (220)	5.28 (135)	48.34 (1228)	183 (84)
CRN 5-22	7 1/2	1	•	34.96 (888)	10.22 (260)	7.62 (194)	50.49 (1283)	292 (133)
		3	•	34.96 (888)	8.66 (220)	5.28 (135)	50.47 (1282)	279 (127)
CRN 5-24	7 1/2	1	•	37.09 (943)	10.22 (260)	7.62 (194)	52.62 (1337)	295 (134)
		3	•	37.09 (943)	8.66 (220)	5.28 (135)	52.60 (1337)	282 (128)

All dimensions in inches unless otherwise noted.

* PJE flanged pump B1 and B1+B2 dimension is one inch less than ANSI flanged pumps and weight is approximately 9 lbs. less.

• Available.

CR 10

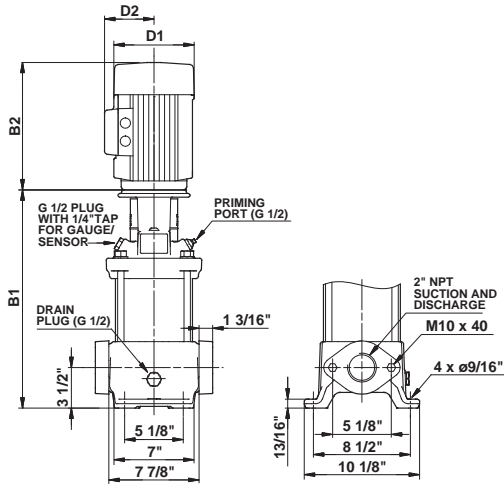

TM03 1460 2205

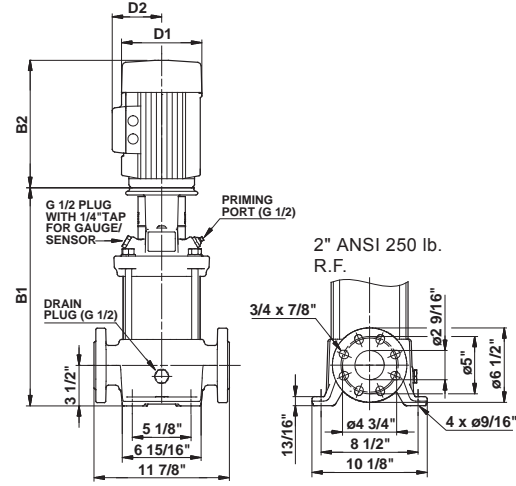

TM03 1461 2205

Pump type	P2 [Hp]	Ph.	Oval*	ANSI dimensions [inch (mm)]								Ship. wt. [lbs (kg)]
				B1	TEFC			ODP				
					D1	D2	B1+B2	D1	D2	B1+B2		
CR 10-1	3/4	1	●	15.28 (389)	6.19 (158)	5.18 (132)	25.19 (640)	-	-	-	115 (53)	
				15.28 (389)	5.55 (141)	4.57 (117)	22.72 (578)	-	-	-	106 (49)	
CR 10-2	1 1/2	1	●	15.28 (389)	7.19 (183)	5.73 (146)	26.96 (685)	-	-	-	128 (59)	
				15.28 (389)	5.55 (141)	4.57 (117)	23.90 (608)	-	-	-	106 (49)	
CR 10-3	3	1	●	17.20 (437)	8.60 (219)	6.87 (175)	31.85 (809)	-	-	-	183 (84)	
				17.20 (437)	7.01 (179)	4.33 (110)	30.43 (773)	-	-	-	153 (70)	
CR 10-4	3	1	●	18.39 (468)	8.60 (219)	6.87 (175)	33.04 (840)	-	-	-	183 (84)	
				18.39 (468)	7.01 (179)	4.33 (110)	31.62 (804)	-	-	-	156 (71)	
CR 10-5	5	1	●	19.57 (498)	10.62 (270)	7.46 (190)	35.09 (892)	-	-	-	209 (95)	
				19.57 (498)	8.66 (220)	5.28 (135)	35.08 (892)	-	-	-	206 (94)	
CR 10-6	5	1	●	20.75 (528)	10.62 (270)	7.46 (190)	36.27 (922)	-	-	-	212 (97)	
				20.75 (528)	8.66 (220)	5.28 (135)	36.26 (922)	-	-	-	208 (95)	
CR 10-7	7 1/2	1	-	22.25 (566)	10.22 (260)	7.62 (194)	37.78 (960)	-	-	-	232 (106)	
				22.25 (566)	8.66 (220)	5.28 (135)	37.76 (960)	-	-	-	221 (101)	
CR 10-8	7 1/2	1	-	23.43 (596)	10.22 (260)	7.62 (194)	38.96 (990)	-	-	-	234 (107)	
				23.43 (596)	8.66 (220)	5.28 (135)	38.94 (990)	-	-	-	223 (102)	
CR 10-9	7 1/2	1	-	24.61 (626)	10.22 (260)	7.62 (194)	40.14 (1020)	-	-	-	236 (108)	
				24.61 (626)	8.66 (220)	5.28 (135)	40.12 (1020)	-	-	-	225 (103)	
CR 10-10	7 1/2	1	-	25.79 (656)	10.22 (260)	7.62 (194)	41.32 (1050)	-	-	-	238 (108)	
				25.79 (656)	8.66 (220)	5.28 (135)	41.30 (1050)	-	-	-	227 (103)	
CR 10-12	10	1	-	28.15 (716)	10.23 (260)	10.30 (262)	44.22 (1124)	-	-	-	355 (162)	
				28.15 (716)	10.24 (261)	6.26 (160)	42.88 (1090)	-	-	-	232 (106)	
CR 10-14	15	3	-	33.06 (840)	12.36 (314)	8.00 (204)	51.60 (1311)	10.62 (270)	7.33 (187)	49.37 (1254)	414 (188)	
CR 10-16	15	3	-	35.43 (900)	12.36 (314)	8.00 (204)	53.97 (1371)	10.62 (270)	7.33 (187)	51.74 (1315)	422 (192)	
CR 10-17	15	3	-	37.80 (961)	12.36 (314)	8.00 (204)	56.34 (1432)	10.62 (270)	7.33 (187)	54.11 (1375)	426 (194)	

All dimensions in inches unless otherwise noted.

* Oval flanged pump B1 and B1+B2 dimension is equal to ANSI flanged pumps and weight is approximately 3 lbs. less.

- Available.

CRI 10

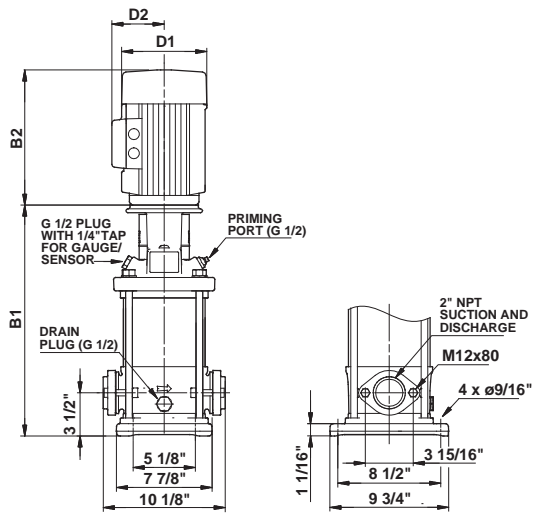

TM03 1458 2205

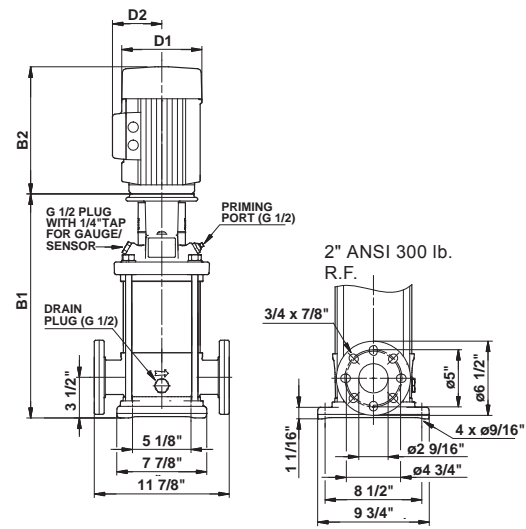

TM03 1458 2205

Pump type	P2 [Hp]	Ph.	Oval*	ANSI dimensions [inch (mm)]							Ship. wt. [lbs (kg)]
				B1	TEFC			ODP			
					D1	D2	B1+B2	D1	D2	B1+B2	
CRI 10-1	1	1	●	15.20 (387)	6.19 (158)	5.18 (132)	25.11 (638)	-	-	-	106 (49)
		3	●	15.20 (387)	5.55 (141)	4.57 (117)	22.64 (576)	-	-	-	98 (45)
CRI 10-2	1 1/2	1	●	15.20 (387)	7.19 (183)	5.73 (146)	26.88 (683)	-	-	-	122 (56)
		3	●	15.20 (387)	5.55 (141)	4.57 (117)	23.82 (606)	-	-	-	100 (46)
CRI 10-3	3	1	●	17.13 (436)	8.60 (219)	6.87 (175)	31.78 (808)	-	-	-	175 (80)
		3	●	17.13 (436)	7.01 (179)	4.33 (110)	30.36 (772)	-	-	-	147 (67)
CRI 10-4	3	1	●	18.31 (466)	8.60 (219)	6.87 (175)	32.96 (838)	-	-	-	177 (81)
		3	●	18.31 (466)	7.01 (179)	4.33 (110)	31.54 (802)	-	-	-	147 (67)
CRI 10-5	5	1	●	19.49 (496)	10.62 (270)	7.46 (190)	35.01 (890)	-	-	-	203 (93)
		3	●	19.49 (496)	8.66 (220)	5.28 (135)	35.00 (889)	-	-	-	199 (91)
CRI 10-6	5	1	●	20.67 (526)	10.62 (270)	7.46 (190)	36.19 (920)	-	-	-	206 (94)
		3	●	20.67 (526)	8.66 (220)	5.28 (135)	36.18 (919)	-	-	-	202 (92)
CRI 10-7	7 1/2	1	●	22.17 (564)	10.22 (260)	7.62 (194)	37.70 (958)	-	-	-	225 (103)
		3	●	22.17 (564)	8.66 (220)	5.28 (135)	37.68 (958)	-	-	-	212 (97)
CRI 10-8	7 1/2	1	●	23.35 (594)	10.22 (260)	7.62 (194)	38.88 (988)	-	-	-	228 (103)
		3	●	23.35 (594)	8.66 (220)	5.28 (135)	38.86 (988)	-	-	-	214 (98)
CRI 10-9	7 1/2	1	●	24.53 (624)	10.22 (260)	7.62 (194)	40.06 (1018)	-	-	-	230 (105)
		3	●	24.53 (624)	8.66 (220)	5.28 (135)	40.04 (1018)	-	-	-	217 (99)
CRI 10-10	7 1/2	1	●	25.71 (654)	10.22 (260)	7.62 (194)	41.24 (1048)	-	-	-	232 (106)
		3	●	25.71 (654)	8.66 (220)	5.28 (135)	41.22 (1047)	-	-	-	219 (100)
CRI 10-12	10	1	-	28.07 (713)	10.23 (260)	10.30 (262)	44.14 (1122)	-	-	-	347 (158)
		3	-	28.07 (713)	10.24 (261)	6.26 (160)	42.80 (1088)	-	-	-	225 (103)
CRI 10-14	15	3	-	32.95 (837)	12.36 (314)	8.00 (204)	51.49 (1308)	10.62 (270)	7.33 (187)	49.26 (1252)	403 (183)
CRI 10-16	15	3	-	35.31 (897)	12.36 (314)	8.00 (204)	53.85 (1368)	10.62 (270)	7.33 (187)	51.62 (1312)	413 (188)
CRI 10-17	15	3	-	37.68 (958)	12.36 (314)	8.00 (204)	56.22 (1428)	10.62 (270)	7.33 (187)	53.99 (1372)	418 (190)

All dimensions in inches unless otherwise noted.
 * Oval flanged pump B1 and B1+B2 dimension is equal to ANSI flanged pumps and weight is approximately 7 lbs. less.
 ● Available.

CRN 10

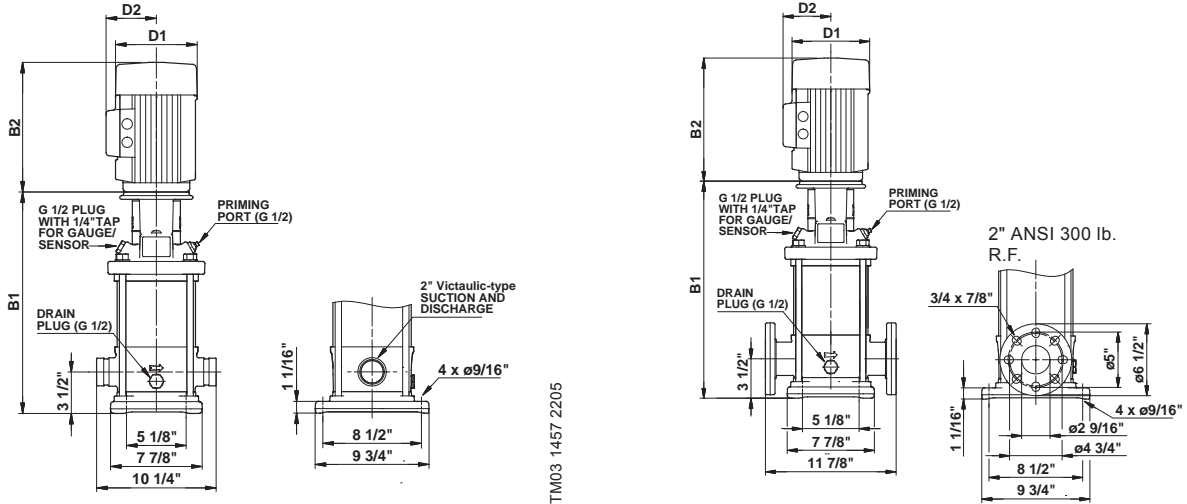

Pump type	P2 [Hp]	Ph.	PJE*	ANSI dimensions [inch (mm)]							Ship. wt. [lbs (kg)]
				B1	TEFC			ODP			
					D1	D2	B1+B2	D1	D2	B1+B2	
CRN 10-1	3/4	1	•	15.20 (387)	6.19 (158)	5.18 (132)	25.11 (638)	-	-	-	106 (49)
		3	•	15.20 (387)	5.55 (141)	4.57 (117)	22.64 (576)	-	-	-	97 (44)
CRN 10-2	1 1/2	1	•	15.20 (387)	7.19 (183)	5.73 (146)	26.88 (683)	-	-	-	121 (55)
		3	•	15.20 (387)	5.55 (141)	4.57 (117)	23.82 (606)	-	-	-	99 (45)
CRN 10-3	3	1	•	17.13 (436)	8.60 (219)	6.87 (175)	31.78 (808)	-	-	-	176 (80)
		3	•	17.13 (436)	7.01 (179)	4.33 (110)	30.36 (772)	-	-	-	147 (67)
CRN 10-4	3	1	•	18.31 (466)	8.60 (219)	6.87 (175)	32.96 (838)	-	-	-	176 (80)
		3	•	18.31 (466)	7.01 (179)	4.33 (110)	31.54 (802)	-	-	-	149 (68)
CRN 10-5	5	1	•	19.49 (496)	10.62 (270)	7.46 (190)	35.01 (890)	-	-	-	203 (93)
		3	•	19.49 (496)	8.66 (220)	5.28 (135)	35.00 (889)	-	-	-	199 (91)
CRN 10-6	5	1	•	20.67 (526)	10.62 (270)	7.46 (190)	36.19 (920)	-	-	-	205 (93)
		3	•	20.67 (526)	8.66 (220)	5.28 (135)	36.18 (919)	-	-	-	201 (92)
CRN 10-7	7 1/2	1	•	22.17 (564)	10.22 (260)	7.62 (194)	37.7 (958)	-	-	-	227 (103)
		3	•	22.17 (564)	8.66 (220)	5.28 (135)	37.68 (958)	-	-	-	214 (98)
CRN 10-8	7 1/2	1	•	23.35 (594)	10.22 (260)	7.62 (194)	38.88 (988)	-	-	-	229 (104)
		3	•	23.35 (594)	8.66 (220)	5.28 (135)	38.86 (988)	-	-	-	216 (98)
CRN 10-9	7 1/2	1	•	24.53 (624)	10.22 (260)	7.62 (194)	40.06 (1018)	-	-	-	232 (106)
		3	•	24.53 (624)	8.66 (220)	5.28 (135)	40.04 (1018)	-	-	-	218 (99)
CRN 10-10	7 1/2	1	•	25.71 (654)	10.22 (260)	7.62 (194)	41.24 (1048)	-	-	-	234 (107)
		3	•	25.71 (654)	8.66 (220)	5.28 (135)	41.22 (1047)	-	-	-	221 (101)
CRN 10-12	10	1	•	28.07 (713)	10.23 (260)	10.30 (262)	44.14 (1122)	-	-	-	346 (157)
		3	•	28.07 (713)	10.24 (261)	6.26 (160)	42.80 (1088)	-	-	-	225 (103)
CRN 10-14	15	3	•	32.95 (837)	12.36 (314)	8.00 (204)	51.49 (1308)	10.62 (270)	7.33 (187)	49.25 (1251)	403 (183)
CRN 10-16	15	3	•	35.31 (897)	12.36 (314)	8.00 (204)	53.85 (1368)	10.62 (270)	7.33 (187)	51.63 (1312)	413 (188)
CRN 10-17	15	3	•	37.68 (958)	12.36 (314)	8.00 (204)	56.22 (1428)	10.62 (270)	7.33 (187)	54.00 (1372)	418 (190)

All dimensions in inches unless otherwise noted.

* PJE flanged pump B1 and B1+B2 dimension is equal to ANSI flanged pumps and weight is approximately 9 lbs. less.

- Available.

CR 15

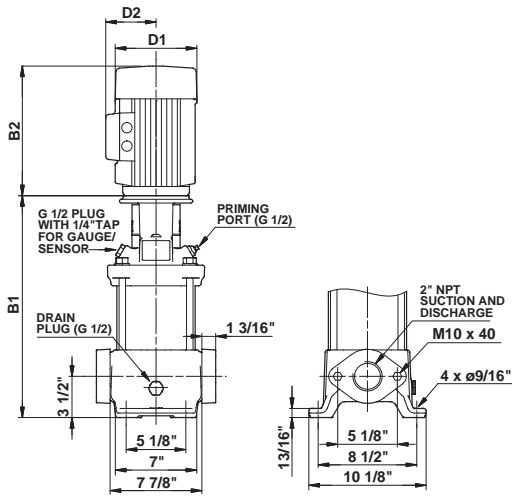

TM03 1460 2205

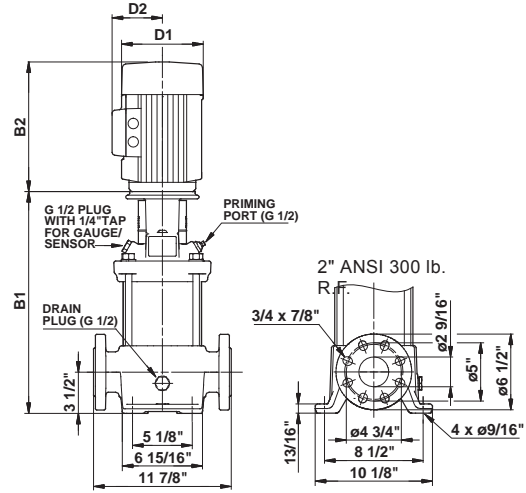

TM03 1461 2205

Pump type	P2 [Hp]	Ph.	Oval*	ANSI dimensions [inch (mm)]									Ship. wt. [lbs (kg)]
				B1	TEFC			ODP					
					D1	D2	B1+B2	D1	D2	B1+B2			
CR 15-1	2	1	●	16.46 (419)	7.19 (183)	5.73 (146)	29.02 (738)	-	-	-	139 (64)		
		3	●	16.46 (419)	7.01 (179)	4.33 (110)	27.68 (704)	-	-	-	128 (59)		
CR 15-2	5	1	●	17.20 (437)	10.62 (270)	7.46 (190)	32.72 (832)	-	-	-	205 (93)		
		3	●	17.20 (437)	8.66 (220)	5.28 (135)	32.71 (831)	-	-	-	201 (92)		
CR 15-3	7 1/2	1	●	19.29 (490)	10.22 (260)	7.62 (194)	34.82 (885)	-	-	-	223 (102)		
		3	●	19.29 (490)	8.66 (220)	5.28 (135)	34.80 (884)	-	-	-	212 (97)		
CR 15-4	7 1/2	1	●	21.06 (535)	10.22 (260)	7.62 (194)	36.59 (930)	-	-	-	225 (103)		
		3	●	21.06 (535)	8.66 (220)	5.28 (135)	36.57 (929)	-	-	-	214 (98)		
CR 15-5	10	1	●	22.83 (580)	10.23 (260)	10.30 (262)	38.90 (989)	-	-	-	342 (156)		
		3	●	22.83 (580)	10.24 (261)	6.26 (160)	37.56 (955)	-	-	-	218 (99)		
CR 15-6	15	3	-	27.17 (691)	12.36 (314)	8.00 (204)	45.71 (1162)	10.62 (270)	7.33 (187)	43.48 (1105)	347 (158)		
CR 15-7	15	3	-	28.94 (736)	12.36 (314)	8.00 (204)	47.48 (1206)	10.62 (270)	7.33 (187)	45.25 (1150)	378 (172)		
CR 15-8	15	3	-	30.71 (781)	12.36 (314)	8.00 (204)	49.25 (1251)	10.62 (270)	7.33 (187)	47.02 (1195)	409 (186)		
CR 15-9	20	3	-	32.48 (825)	12.36 (314)	8.00 (204)	51.02 (1296)	11.50 (293)	8.92 (227)	52.17 (1326)	417 (190)		
CR 15-10	20	3	-	34.25 (870)	12.36 (314)	8.00 (204)	52.79 (1341)	11.50 (293)	8.92 (227)	53.94 (1371)	421 (191)		
CR 15-12	25	3	-	37.17 (945)	12.36 (314)	8.00 (204)	59.56 (1513)	11.50 (293)	8.94 (228)	57.98 (1473)	422 (192)		

All dimensions in inches unless otherwise noted.

* Oval flanged pump B1 and B1+B2 dimension is equal to ANSI flanged pumps and weight is approximately 3 lbs. less.

- Available.

CRI 15

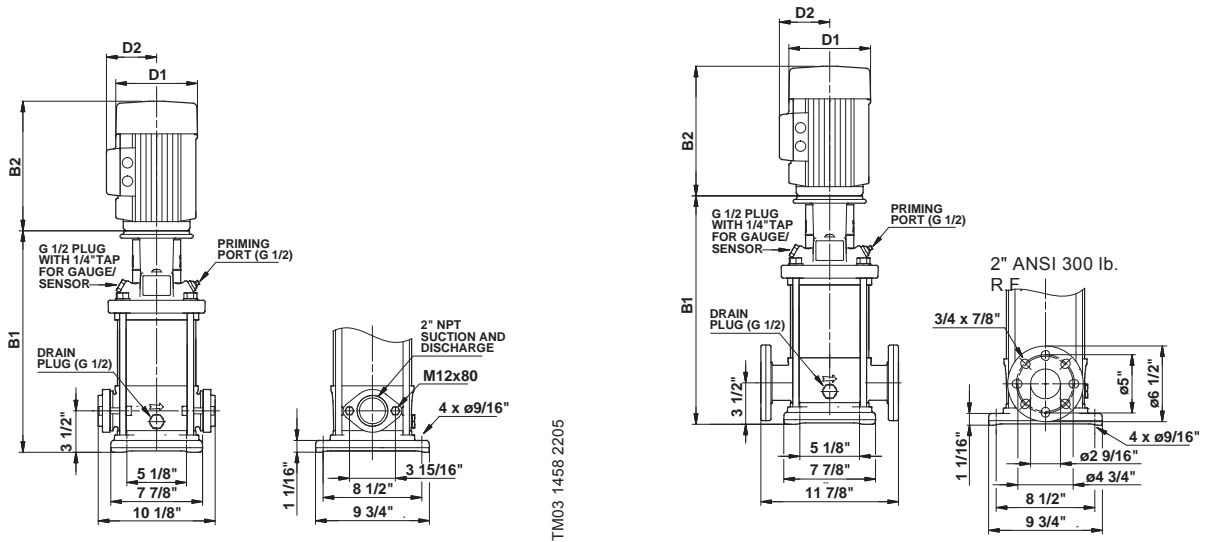

TM03 1458 2205

TM03 1459 2205

Pump type	P2 [Hp]	Ph.	Oval*	ANSI dimensions [inch (mm)]						Ship. wt. [lbs (kg)]	
				B1	TEFC			ODP			
					D1	D2	B1+B2	D1	D2		B1+B2
CRI 15-1	2	1 3	•	16.38 (417)	7.19 (183)	5.73 (146)	28.94 (736)	-	-	-	130 (59)
CRI 15-2	5	1 3	•	16.38 (417)	7.01 (179)	4.33 (110)	27.60 (702)	-	-	-	121 (55)
CRI 15-3	7 1/2	1 3	•	17.13 (436)	10.62 (270)	7.46 (190)	32.65 (830)	-	-	-	198 (90)
CRI 15-4	7 1/2	1 3	•	17.13 (436)	8.66 (220)	5.28 (135)	32.64 (830)	-	-	-	195 (89)
CRI 15-5	10	1 3	•	19.21 (488)	10.22 (260)	7.62 (194)	34.74 (883)	-	-	-	216 (98)
CRI 15-6	15	1 3	•	19.21 (488)	8.66 (220)	5.28 (135)	34.72 (882)	-	-	-	203 (93)
CRI 15-7	15	1 3	•	20.98 (533)	10.22 (260)	7.62 (194)	36.51 (928)	-	-	-	218 (99)
CRI 15-8	15	1 3	•	20.98 (533)	8.66 (220)	5.28 (135)	36.49 (927)	-	-	-	205 (93)
CRI 15-9	20	1 3	•	22.76 (579)	10.23 (260)	10.30 (262)	38.83 (987)	-	-	-	333 (152)
CRI 15-10	20	1 3	•	22.76 (579)	10.24 (261)	6.26 (160)	37.49 (953)	-	-	-	212 (97)
CRI 15-11	25	1 3	•	27.05 (688)	12.36 (314)	8.00 (204)	45.59 (1158)	10.62 (270)	7.33 (187)	43.36 (1102)	336 (153)
CRI 15-12	25	1 3	•	28.82 (733)	12.36 (314)	8.00 (204)	47.36 (1203)	10.62 (270)	7.33 (187)	45.13 (1147)	369 (168)
CRI 15-13	30	1 3	•	30.59 (777)	12.36 (314)	8.00 (204)	49.13 (1248)	10.62 (270)	7.33 (187)	46.90 (1192)	402 (183)
CRI 15-14	40	1 3	-	32.36 (822)	12.36 (314)	8.00 (204)	50.90 (1293)	11.50 (293)	8.92 (227)	52.05 (1323)	410 (186)
CRI 15-15	50	1 3	-	34.13 (867)	12.36 (314)	8.00 (204)	52.67 (1338)	11.50 (293)	8.92 (227)	53.82 (1368)	413 (188)
CRI 15-16	75	1 3	-	37.05 (942)	12.36 (314)	8.00 (204)	59.44 (1510)	11.50 (293)	8.94 (228)	57.86 (1470)	413 (188)

All dimensions in inches unless otherwise noted.

* Oval flanged pump B1 and B1+B2 dimension is equal to ANSI flanged pumps and weight is approximately 7 lbs. less.

- Available.

CRN 15

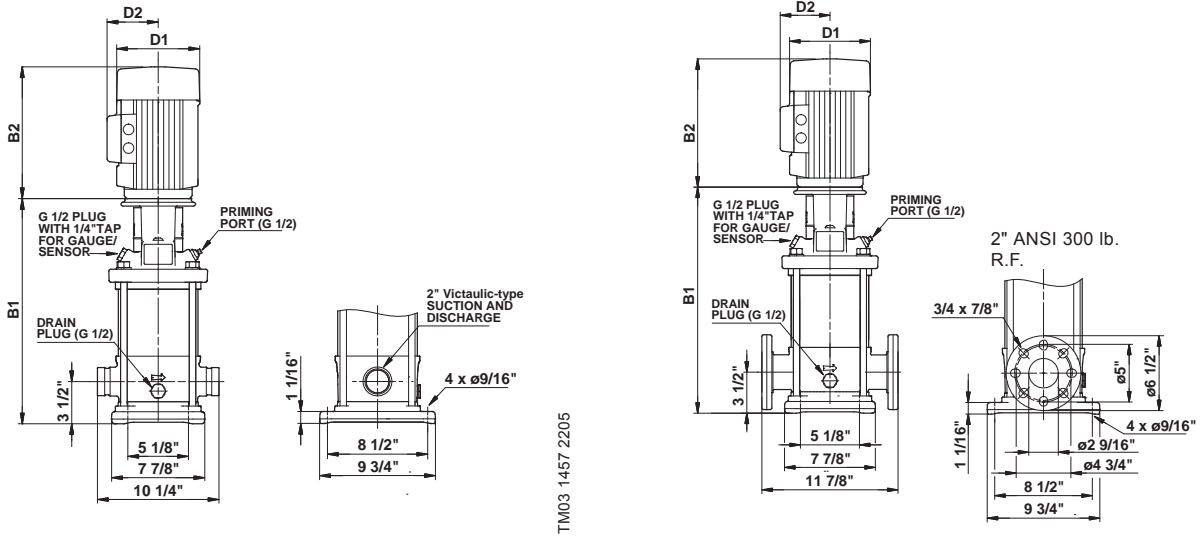

TM03 1457 2205

TM03 1459 2205

Pump type	P2 [Hp]	Ph.	PJE*	ANSI dimensions [inch (mm)]									Ship. wt. [lbs (kg)]
				B1	TEFC			ODP					
					D1	D2	B1+B2	D1	D2	B1+B2			
CRN 15-1	2	1	•	16.38 (417)	7.19 (183)	5.73 (146)	28.94 (736)	-	-	-	130 (59)		
		3	•	16.38 (417)	7.01 (179)	4.33 (110)	27.6 (702)	-	-	-	121 (55)		
CRN 15-2	5	1	•	17.44 (443)	10.62 (270)	7.46 (190)	32.96 (838)	-	-	-	203 (93)		
		3	•	17.13 (436)	8.66 (220)	5.28 (135)	32.64 (830)	-	-	-	195 (89)		
CRN 15-3	7 1/2	1	•	19.21 (488)	10.22 (260)	7.62 (194)	34.74 (883)	-	-	-	216 (98)		
		3	•	19.21 (488)	8.66 (220)	5.28 (135)	34.72 (882)	-	-	-	205 (93)		
CRN 15-4	7 1/2	1	•	20.98 (533)	10.22 (260)	7.62 (194)	36.51 (928)	-	-	-	218 (99)		
		3	•	20.98 (533)	8.66 (220)	5.28 (135)	36.49 (927)	-	-	-	207 (94)		
CRN 15-5	10	1	•	22.76 (579)	10.23 (260)	10.30 (262)	38.83 (987)	-	-	-	335 (152)		
		3	•	22.76 (579)	10.24 (261)	6.26 (160)	37.49 (953)	-	-	-	214 (98)		
CRN 15-6	15	3	•	27.05 (688)	12.36 (314)	8.00 (204)	45.59 (1158)	10.62 (270)	7.33 (187)	43.36 (1102)	336 (153)		
CRN 15-7	15	3	•	28.82 (733)	12.36 (314)	8.00 (204)	47.36 (1203)	10.62 (270)	7.33 (187)	45.13 (1147)	369 (168)		
CRN 15-8	15	3	•	30.59 (777)	12.36 (314)	8.00 (204)	49.13 (1248)	10.62 (270)	7.33 (187)	46.90 (1192)	402 (183)		
CRN 15-9	20	3	•	32.36 (822)	12.36 (314)	8.00 (204)	50.90 (1293)	11.50 (293)	8.92 (227)	52.05 (1323)	410 (186)		
CRN 15-10	20	3	•	34.13 (867)	12.36 (314)	8.00 (204)	52.67 (1338)	11.50 (293)	8.92 (227)	53.82 (1368)	413 (188)		
CRN 15-12	25	3	•	37.05 (942)	12.36 (314)	8.00 (204)	59.44 (1510)	11.50 (293)	8.94 (228)	57.86 (1470)	413 (188)		

All dimensions in inches unless otherwise noted.

* PJE flanged pump B1 and B1+B2 dimension is equal to ANSI flanged pump and weight is approximately 9 lbs. less.

- Available.

CR 20

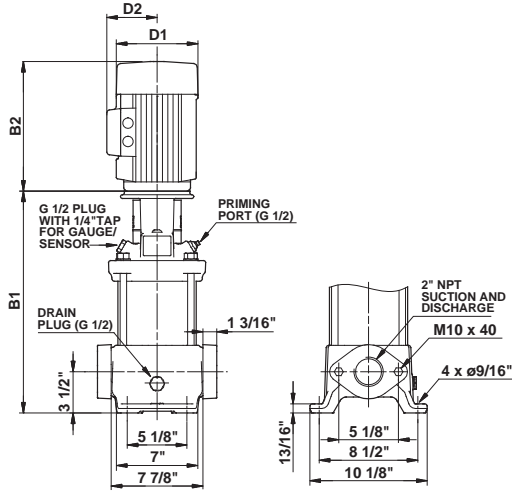

TM03 1460 2205

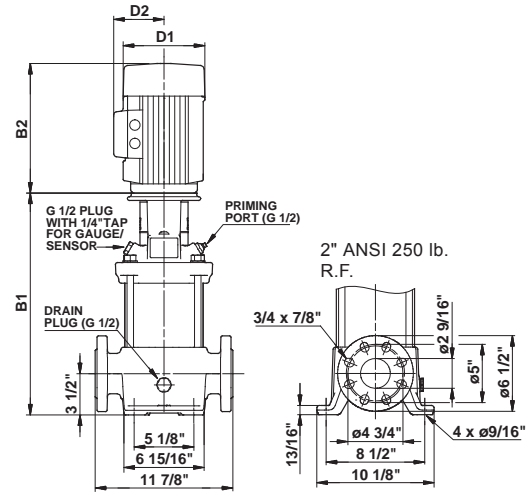

TM03 1461 2205

Pump type	P2 [Hp]	Ph.	ANSI dimensions [inch (mm)]								
			Oval*	B1	TEFC			ODP			Ship. wt. [lbs (kg)]
					D1	D2	B1+B2	D1	D2	B1+B2	
CR 20-1	3	1 3	● ●	17.20 (437) 17.20 (437)	8.60 (219) 7.01 (179)	6.87 (175) 4.33 (110)	31.85 (809) 30.43 (773)	- -	- -	- -	181 (83) 151 (69)
CR 20-2	5	1 3	● ●	17.20 (437) 17.20 (437)	10.62 (270) 8.66 (220)	7.46 (190) 5.28 (135)	32.72 (832) 32.71 (831)	- -	- -	- -	205 (93) 201 (92)
CR 20-3	7 1/2	1 3	● ●	19.29 (490) 19.29 (490)	10.22 (260) 8.66 (220)	7.62 (194) 5.28 (135)	34.82 (885) 34.80 (884)	- -	- -	- -	223 (102) 209 (95)
CR 20-4	10	1 3	● ●	21.06 (535) 21.06 (535)	10.23 (260) 10.24 (261)	10.30 (262) 6.26 (160)	37.13 (944) 35.79 (910)	- -	- -	- -	337 (153) 214 (98)
CR 20-5	15	3	●	25.39 (645)	12.36 (314)	8.00 (204)	43.93 (1116)	10.62 (270)	7.33 (187)	41.70 (1060)	369 (168)
CR 20-6	15	3	●	27.17 (691)	12.36 (314)	8.00 (204)	45.71 (1162)	10.62 (270)	7.33 (187)	43.48 (1105)	373 (170)
CR 20-7	20	3	●	28.94 (736)	12.36 (314)	8.00 (204)	47.48 (1206)	11.5 (293)	8.92 (227)	48.63 (1236)	409 (186)
CR 20-8	20	3	-	30.71 (781)	12.36 (314)	8.00 (204)	49.25 (1251)	11.5 (293)	8.92 (227)	50.40 (1281)	413 (188)
CR 20-10	25	3	-	33.62 (854)	12.36 (314)	8.00 (204)	56.01 (1423)	11.5 (293)	8.94 (228)	54.43 (1383)	413 (188)

All dimensions in inches unless otherwise noted.

* Oval flanged pump B1 and B1+B2 dimension is equal to ANSI flanged pumps and weight is approximately 3 lbs. less.

● Available.

CRI 20

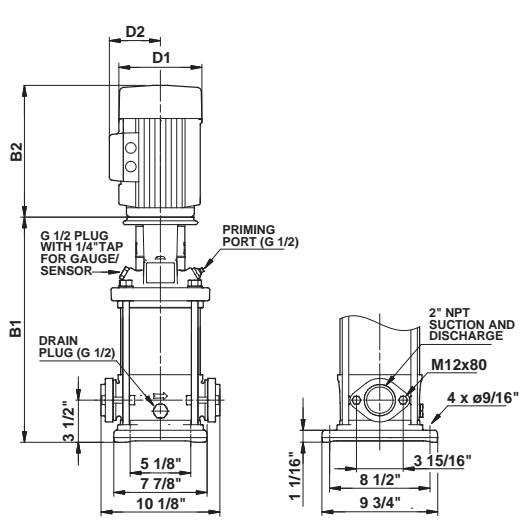

TM03 1458 2205

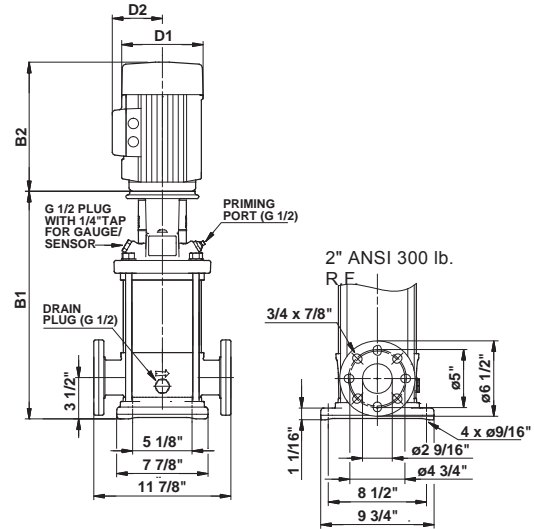

TM03 1459 2205

Pump type	P2 [Hp]	Ph.	ANSI dimensions [inch (mm)]									Ship. wt. [lbs (kg)]
			Oval*	B1	TEFC			ODP				
					D1	D2	B1+B2	D1	D2	B1+B2		
CRI 20-1	3	1	●	17.13 (436)	8.60 (219)	6.87 (175)	31.78 (808)	-	-	-	174 (79)	
		3	●	17.13 (436)	7.01 (179)	4.33 (110)	30.36 (772)	-	-	-	145 (66)	
CRI 20-2	5	1	●	17.13 (436)	10.62 (270)	7.46 (190)	32.65 (830)	-	-	-	198 (90)	
		3	●	17.13 (436)	8.66 (220)	5.28 (135)	32.64 (830)	-	-	-	195 (89)	
CRI 20-3	7 1/2	1	●	19.21 (488)	10.22 (260)	7.62 (194)	34.74 (883)	-	-	-	216 (98)	
		3	●	19.21 (488)	8.66 (220)	5.28 (135)	34.72 (882)	-	-	-	203 (93)	
CRI 20-4	10	1	●	20.98 (533)	10.23 (260)	10.30 (262)	37.05 (942)	-	-	-	331 (151)	
		3	●	20.98 (533)	10.24 (261)	6.26 (160)	35.71 (908)	-	-	-	205 (93)	
CRI 20-5	15	3	●	25.28 (643)	12.36 (314)	8.00 (204)	43.82 (1114)	10.62 (270)	7.33 (187)	41.59 (1057)	362 (165)	
CRI 20-6	15	3	●	27.05 (688)	12.36 (314)	8.00 (204)	45.59 (1158)	10.62 (270)	7.33 (187)	43.36 (1102)	367 (167)	
CRI 20-7	20	3	●	28.82 (733)	12.36 (314)	8.00 (204)	47.36 (1203)	11.50 (293)	8.92 (227)	48.51 (1233)	402 (185)	
CRI 20-8	20	3	-	30.59 (777)	12.36 (314)	8.00 (204)	49.13 (1248)	11.50 (293)	8.92 (227)	50.28 (1278)	406 (185)	
CRI 20-10	25	3	-	33.50 (851)	12.36 (314)	8.00 (204)	55.89 (1420)	11.50 (293)	8.94 (228)	54.31 (1380)	407 (185)	

All dimensions in inches unless otherwise noted.

* Oval flanged pump B1 and B1+B2 dimension is equal to ANSI flanged pumps and weight is approximately 7 lbs. less.

- Available.

CRN 20

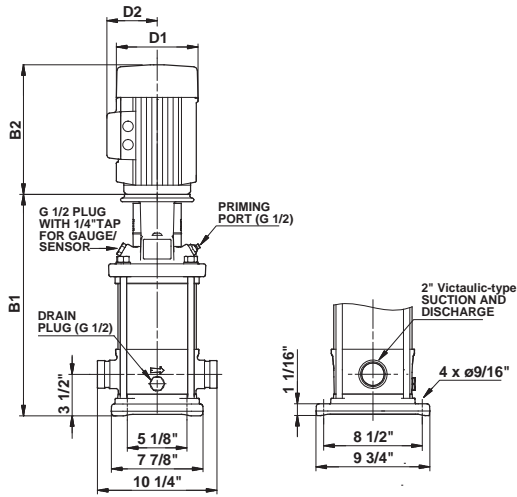

TM03 1457 2205

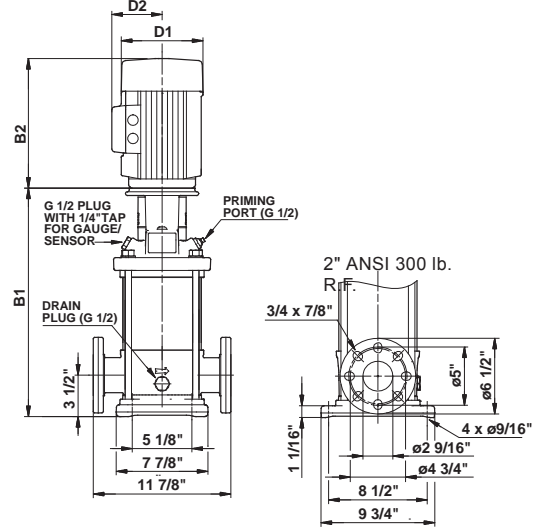

TM03 1459 2205

Pump type	P2 [Hp]	Ph.	ANSI dimensions [inch (mm)]									Ship. wt. [lbs (kg)]
			PJE*	B1	TEFC			ODP				
					D1	D2	B1+B2	D1	D2	B1+B2		
CRN 20-1	3	1 3	• •	17.13 (436) 17.13 (436)	8.60 (219) 7.01 (179)	6.87 (175) 4.33 (110)	31.78 (808) 30.36 (772)	- -	- -	- -	174 (79) 145 (66)	
CRN 20-2	5	1 3	• •	17.13 (436) 17.13 (436)	10.62 (270) 8.66 (220)	7.46 (190) 5.28 (135)	32.65 (830) 32.64 (830)	- -	- -	- -	198 (90) 195 (89)	
CRN 20-3	7 1/2	1 3	• •	19.21 (488) 19.21 (488)	10.22 (260) 8.66 (220)	7.62 (194) 5.28 (135)	34.74 (883) 34.72 (882)	- -	- -	- -	216 (98) 203 (93)	
CRN 20-4	10	1 3	• •	20.98 (533) 20.98 (533)	10.23 (260) 10.24 (261)	10.30 (262) 6.26 (160)	37.05 (942) 35.71 (908)	- -	- -	- -	331 (151) 207 (94)	
CRN 20-5	15	3	•	25.28 (643)	12.36 (314)	8.00 (204)	43.82 (1114)	10.62 (270)	7.33 (187)	41.59 (1057)	365 (166)	
CRN 20-6	15	3	•	27.05 (688)	12.36 (314)	8.00 (204)	45.59 (1158)	10.62 (270)	7.33 (187)	43.36 (1102)	367 (167)	
CRN 20-7	20	3	•	28.82 (733)	12.36 (314)	8.00 (204)	47.36 (1203)	11.50 (293)	8.92 (227)	48.51 (1233)	402 (183)	
CRN 20-8	20	3	•	30.59 (777)	12.36 (314)	8.00 (204)	49.13 (1248)	11.50 (293)	8.92 (227)	50.28 (1278)	406 (185)	
CRN 20-10	25	3	•	33.50 (851)	12.36 (314)	8.00 (204)	55.89 (1420)	11.50 (293)	8.94 (228)	54.31 (1380)	407 (185)	

All dimensions in inches unless otherwise noted.

* PJE flanged pump B1 and B1+B2 dimension is equal to ANSI flanged pumps and weight is approximately 9 lbs. less.

• Available.

CR 32

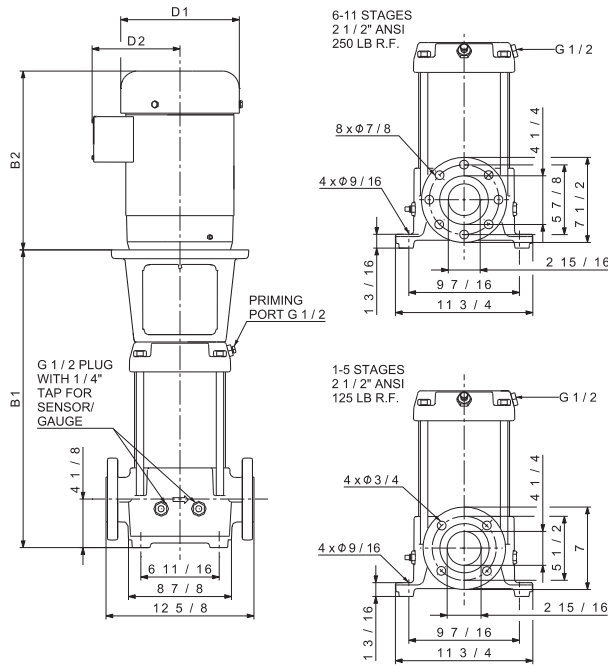

TM02 7699 1009

Pump type	P2 [Hp]	Ph.	ANSI dimensions [inch (mm)]						Ship. wt. ¹⁾ [lbs (kg)]	
			B1	TEFC			ODP			
				D1	D2	B1+B2	D1	D2		B1+B2
CR 32-1-1	5	1	20.08 (511)	10.62 (270)	7.46 (190)	35.60 (905)	-	-	-	240 (109)
		3	19.88 (505)	8.66 (220)	5.28 (135)	35.39 (899)	-	-	-	218 (99)
CR 32-1	5	1	20.08 (511)	10.62 (270)	7.46 (190)	35.60 (905)	-	-	-	228 (104)
		3	19.88 (505)	8.66 (220)	5.28 (135)	35.39 (899)	-	-	-	218 (99)
CR 32-2-2	7 1/2	1	22.83 (580)	10.22 (260)	7.62 (194)	38.36 (975)	-	-	-	245 (112)
		3	22.64 (576)	8.66 (220)	5.28 (135)	38.15 (970)	-	-	-	229 (104)
CR 32-2-1	7 1/2	1	22.83 (580)	10.22 (260)	7.62 (194)	38.36 (975)	-	-	-	245 (112)
		3	22.64 (576)	8.66 (220)	5.28 (135)	38.15 (970)	-	-	-	229 (104)
CR 32-2	10	1	22.83 (580)	10.23 (260)	10.30 (262)	38.90 (989)	-	-	-	300 (137)
		3	22.64 (576)	10.24 (261)	6.26 (160)	37.87 (962)	-	-	-	229 (104)
CR 32-3-2	10	1	25.59 (650)	10.23 (260)	10.30 (262)	41.66 (1059)	-	-	-	295 (134)
		3	25.39 (645)	10.24 (261)	6.26 (160)	40.12 (1020)	-	-	-	236 (108)
CR 32-3	15	3	29.72 (755)	12.36 (314)	8.00 (204)	48.26 (1226)	10.62 (270)	7.33 (187)	46.03 (1170)	332 (151)
CR 32-4-2	15	3	32.48 (825)	12.36 (314)	8.00 (204)	51.02 (1296)	10.62 (270)	7.33 (187)	48.79 (1240)	339 (154)
CR 32-4	20	3	32.48 (825)	12.36 (314)	8.00 (204)	51.02 (1296)	11.50 (293)	8.92 (227)	52.17 (1326)	344 (157)
CR 32-5-2	20	3	35.24 (896)	12.36 (314)	8.00 (204)	53.78 (1367)	11.50 (293)	8.92 (227)	54.93 (1396)	351 (160)
CR 32-5	20	3	35.24 (896)	12.36 (314)	8.00 (204)	53.78 (1367)	11.50 (293)	8.92 (227)	54.93 (1396)	351 (160)
CR 32-6-2	25	3	37.99 (965)	12.36 (314)	8.00 (204)	60.38 (1534)	11.50 (293)	8.94 (228)	58.80 (1494)	351 (160)
CR 32-6	25	3	37.99 (965)	12.36 (314)	8.00 (204)	60.38 (1534)	11.50 (293)	8.94 (228)	58.80 (1494)	351 (160)
CR 32-7-2	30	3	40.75 (1036)	12.36 (314)	8.00 (204)	63.14 (1604)	11.50 (293)	8.94 (228)	62.56 (1590)	444 (202)
CR 32-7	30	3	40.75 (1036)	12.36 (314)	8.00 (204)	63.14 (1604)	11.50 (293)	8.94 (228)	62.56 (1590)	423 (192)
CR 32-8-2	30	3	43.50 (1105)	12.36 (314)	8.00 (204)	65.89 (1674)	11.50 (293)	8.94 (228)	65.31 (1659)	436 (198)
CR 32-8	40	3	43.50 (1105)	15.32 (390)	13.11 (333)	66.69 (1694)	13.25 (337)	12.21 (311)	66.75 (1696)	631 (287)
CR 32-9-2	40	3	46.26 (1176)	15.32 (390)	13.11 (333)	69.45 (1765)	13.25 (337)	12.21 (311)	69.51 (1766)	637 (289)
CR 32-9	40	3	46.26 (1176)	15.32 (390)	13.11 (333)	69.45 (1765)	13.25 (337)	12.21 (311)	69.51 (1766)	637 (289)
CR 32-10-2	40	3	49.02 (1246)	15.32 (390)	13.11 (333)	72.21 (1835)	13.25 (337)	12.21 (311)	72.27 (1836)	645 (293)
CR 32-10	40	3	49.02 (1246)	15.32 (390)	13.11 (333)	72.21 (1835)	13.25 (337)	12.21 (311)	72.27 (1836)	645 (293)
CR 32-11-2	50	3	51.77 (1315)	16.88 (429)	14.12 (359)	79.58 (2022)	13.25 (337)	12.21 (311)	74.52 (1893)	671 (305)

¹⁾ Weights are based on pump with TEFC motor (see price list for individual weights). All dimensions in inches unless otherwise noted.

CRN 32

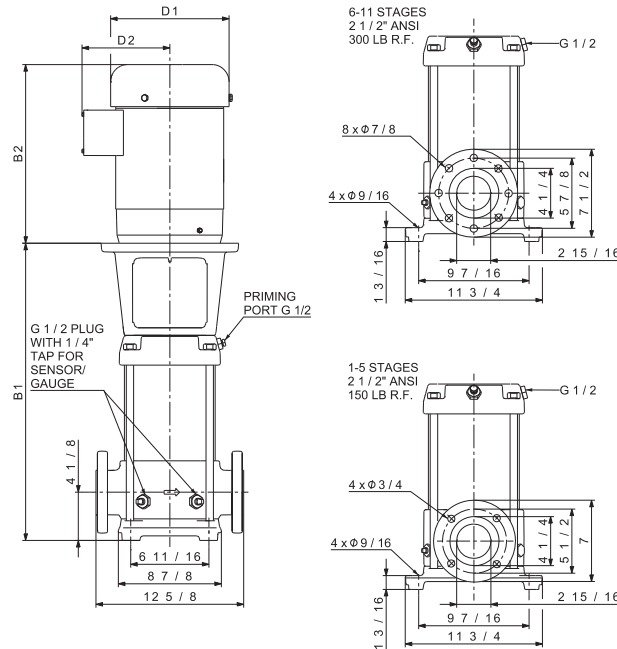

TM02 7703 1009

Pump type	P2 [Hp]	Ph.	ANSI dimensions [inch (mm)]						Ship. wt. ¹⁾ [lbs (kg)]	
			B1	TEFC			ODP			
				D1	D2	B1+B2	D1	D2		B1+B2
CRN 32-1-1	5	1	20.08 (511)	10.62 (270)	7.46 (190)	35.60 (905)	-	-	-	245 (112)
			19.88 (505)	8.66 (220)	5.28 (135)	35.39 (899)	-	-	-	223 (102)
CRN 32-1	5	3	20.08 (511)	10.62 (270)	7.46 (190)	35.60 (905)	-	-	-	233 (106)
			19.88 (505)	8.66 (220)	5.28 (135)	35.39 (899)	-	-	-	223 (102)
CRN 32-2-2	7 1/2	1	22.83 (580)	10.22 (260)	7.62 (194)	38.36 (975)	-	-	-	250 (114)
			22.64 (576)	8.66 (220)	5.28 (135)	38.15 (970)	-	-	-	234 (107)
CRN 32-2-1	7 1/2	3	22.83 (580)	10.22 (260)	7.62 (194)	38.36 (975)	-	-	-	250 (114)
			22.64 (576)	8.66 (220)	5.28 (135)	38.15 (970)	-	-	-	234 (107)
CRN 32-2	10	1	22.83 (580)	10.23 (260)	10.30 (262)	38.90 (989)	-	-	-	305 (139)
			22.64 (576)	10.24 (261)	6.26 (160)	37.37 (950)	-	-	-	234 (107)
CRN 32-3-2	10	3	25.59 (650)	10.23 (260)	10.30 (262)	41.66 (1059)	-	-	-	300 (137)
			25.39 (645)	10.24 (261)	6.26 (160)	40.12 (1020)	-	-	-	241 (110)
CRN 32-3	15	3	29.72 (755)	12.36 (314)	8.00 (204)	48.26 (1226)	10.62 (270)	7.33 (187)	46.03 (1170)	337 (153)
CRN 32-4-2	15	3	32.48 (825)	12.36 (314)	8.00 (204)	51.02 (1296)	10.62 (270)	7.33 (187)	48.79 (1240)	343 (156)
CRN 32-4	20	3	32.48 (825)	12.36 (314)	8.00 (204)	51.02 (1296)	11.50 (293)	8.92 (227)	52.17 (1326)	348 (158)
CRN 32-5-2	20	3	35.24 (896)	12.36 (314)	8.00 (204)	53.78 (1367)	11.50 (293)	8.92 (227)	54.93 (1396)	355 (162)
CRN 32-5	20	3	35.24 (896)	12.36 (314)	8.00 (204)	53.78 (1367)	11.50 (293)	8.92 (227)	54.93 (1396)	355 (162)
CRN 32-6-2	25	3	37.99 (965)	12.36 (314)	8.00 (204)	60.38 (1534)	11.50 (293)	8.94 (228)	58.80 (1494)	355 (162)
CRN 32-6	25	3	37.99 (965)	12.36 (314)	8.00 (204)	60.38 (1534)	11.50 (293)	8.94 (228)	58.80 (1494)	355 (162)
CRN 32-7-2	30	3	40.75 (1036)	12.36 (314)	8.00 (204)	63.14 (1604)	11.50 (293)	8.94 (228)	62.56 (1590)	448 (204)
CRN 32-7	30	3	40.75 (1036)	12.36 (314)	8.00 (204)	63.14 (1604)	11.50 (293)	8.94 (228)	62.56 (1590)	427 (194)
CRN 32-8-2	30	3	43.50 (1105)	12.36 (314)	8.00 (204)	65.89 (1674)	11.50 (293)	8.94 (228)	65.31 (1659)	440 (200)
CRN 32-8	40	3	43.50 (1105)	15.32 (390)	13.11 (333)	66.69 (1694)	13.25 (337)	12.21 (311)	66.75 (1696)	635 (289)
CRN 32-9-2	40	3	46.26 (1176)	15.32 (390)	13.11 (333)	69.45 (1765)	13.25 (337)	12.21 (311)	69.51 (1766)	641 (291)
CRN 32-9	40	3	46.26 (1176)	15.32 (390)	13.11 (333)	69.45 (1765)	13.25 (337)	12.21 (311)	69.51 (1766)	641 (291)
CRN 32-10-2	40	3	49.02 (1246)	15.32 (390)	13.11 (333)	72.21 (1835)	13.25 (337)	12.21 (311)	72.27 (1836)	648 (294)
CRN 32-10	40	3	49.02 (1246)	15.32 (390)	13.11 (333)	72.21 (1835)	13.25 (337)	12.21 (311)	72.27 (1836)	648 (294)
CRN 32-11-2	50	3	51.77 (1315)	16.88 (429)	14.12 (359)	79.58 (2022)	13.25 (337)	12.21 (311)	74.52 (1893)	674 (306)

¹⁾ Weights are based on pump with TEFC motor (see price list for individual weights). All dimensions in inches unless otherwise noted.

CR 45

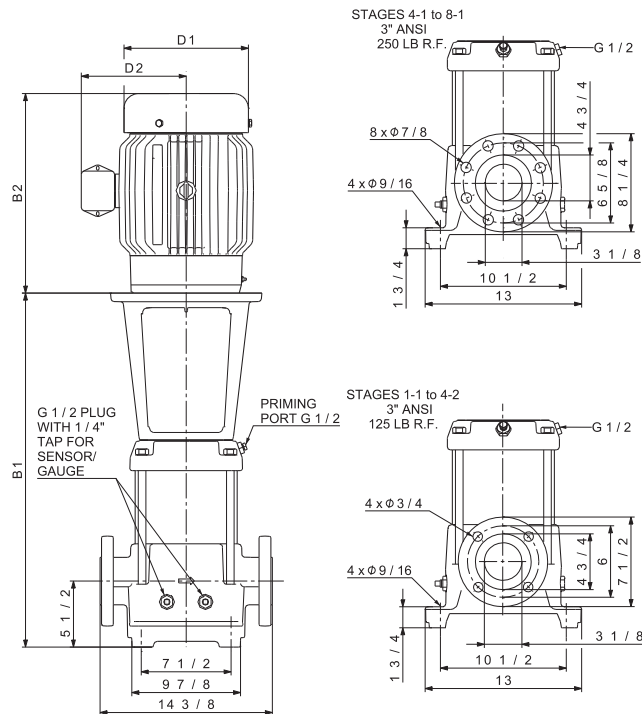

TM02 7700 1009

Pump type	P2 [Hp]	Ph.	ANSI dimensions [inch (mm)]								
			B1	TEFC			ODP			Ship. wt. ¹⁾ [lbs (kg)]	
				D1	D2	B1+B2	D1	D2	B1+B2		
CR 45-1-1	7 1/2	1	22.20 (564)	10.22 (260)	7.62 (194)	37.73 (959)	-	-	-	259 (118)	
		3	22.01 (560)	8.66 (220)	5.28 (135)	37.52 (954)	-	-	-	243 (111)	
CR 45-1	10	1	22.20 (564)	10.23 (260)	10.30 (262)	38.27 (973)	-	-	-	314 (143)	
		3	22.01 (560)	10.24 (261)	6.26 (160)	36.74 (934)	-	-	-	243 (111)	
CR 45-2-2	15	3	29.49 (750)	12.36 (314)	8.00 (204)	48.03 (1220)	10.62 (270)	7.33 (187)	45.80 (1164)	347 (158)	
CR 45-2-1	15	3	29.49 (750)	12.36 (314)	8.00 (204)	48.03 (1220)	10.62 (270)	7.33 (187)	45.80 (1164)	347 (158)	
CR 45-2	15	3	29.49 (750)	12.36 (314)	8.00 (204)	48.03 (1220)	10.62 (270)	7.33 (187)	45.80 (1164)	347 (158)	
CR 45-3-2	20	3	32.64 (830)	12.36 (314)	8.00 (204)	51.18 (1300)	11.50 (293)	8.92 (227)	52.33 (1330)	361 (164)	
CR 45-3-1	25	3	32.64 (830)	12.36 (314)	8.00 (204)	55.03 (1398)	11.50 (293)	8.94 (228)	53.45 (1358)	353 (161)	
CR 45-3	25	3	32.64 (830)	12.36 (314)	8.00 (204)	55.03 (1398)	11.50 (293)	8.94 (228)	53.45 (1358)	353 (161)	
CR 45-4-2	30	3	35.79 (910)	12.36 (314)	8.00 (204)	58.18 (1478)	11.50 (293)	8.94 (228)	57.60 (1464)	426 (194)	
CR 45-4-1	30	3	35.79 (910)	12.36 (314)	8.00 (204)	58.18 (1478)	11.50 (293)	8.94 (228)	57.60 (1464)	432 (196)	
CR 45-4	30	3	35.79 (910)	12.36 (314)	8.00 (204)	58.18 (1478)	11.50 (293)	8.94 (228)	57.60 (1464)	432 (196)	
CR 45-5-2	40	3	38.94 (990)	15.32 (390)	13.11 (333)	62.13 (1579)	13.25 (337)	12.21 (311)	62.19 (1580)	634 (288)	
CR 45-5-1	40	3	38.94 (990)	15.32 (390)	13.11 (333)	62.13 (1579)	13.25 (337)	12.21 (311)	62.19 (1580)	634 (288)	
CR 45-5	40	3	38.94 (990)	15.32 (390)	13.11 (333)	62.13 (1579)	13.25 (337)	12.21 (311)	62.19 (1580)	634 (288)	
CR 45-6-2	50	3	42.09 (1070)	16.88 (429)	14.12 (359)	69.90 (1776)	13.25 (337)	12.21 (311)	64.84 (1647)	679 (308)	
CR 45-6	50	3	42.09 (1070)	16.88 (429)	14.12 (359)	69.90 (1776)	13.25 (337)	12.21 (311)	64.84 (1647)	679 (308)	
CR 45-7-2	50	3	45.24 (1150)	16.88 (429)	14.12 (359)	73.05 (1856)	13.25 (337)	12.21 (311)	67.99 (1727)	689 (313)	
CR 45-7	60	3	45.24 (1150)	19.00 (483)	14.90 (379)	76.03 (1932)	15.12 (385)	13.19 (336)	71.37 (1813)	869 (395)	
CR 45-8-1	60	3	48.39 (1230)	19.00 (483)	14.90 (379)	79.18 (2012)	15.12 (385)	13.19 (336)	74.52 (1893)	878 (399)	

¹⁾ Weights are based on pump with TEFC motor (see price list for individual weights). All dimensions in inches unless otherwise noted.

CRN 45

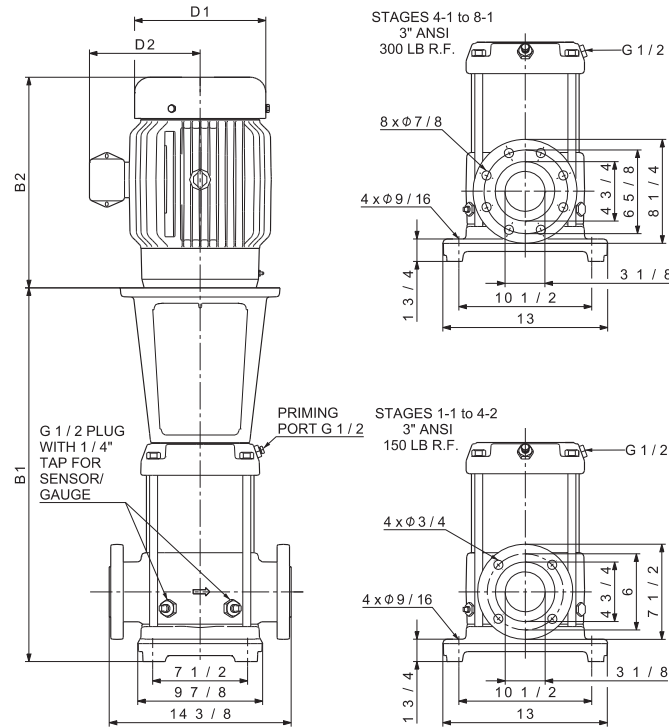

TM02 7704 1009

Pump type	P2 [Hp]	Ph.	ANSI dimensions [inch (mm)]									Ship. wt. ¹⁾ [lbs (kg)]
			B1	TEFC			ODP					
				D1	D2	B1+B2	D1	D2	B1+B2			
CRN 45-1-1	7 1/2	1	22.20 (564)	10.22 (260)	7.62 (194)	37.73 (959)	-	-	-	259 (118)		
		3	22.01 (560)	8.66 (220)	5.28 (135)	37.52 (954)	-	-	-	243 (111)		
CRN 45-1	10	1	22.20 (564)	10.23 (260)	10.30 (262)	38.27 (973)	-	-	-	314 (143)		
		3	22.01 (560)	10.24 (261)	6.26 (160)	36.74 (934)	-	-	-	243 (111)		
CRN 45-2-2	15	3	29.49 (750)	12.36 (314)	8.00 (204)	48.03 (1220)	10.62 (270)	7.33 (187)	45.80 (1164)	347 (158)		
CRN 45-2-1	15	3	29.49 (750)	12.36 (314)	8.00 (204)	48.03 (1220)	10.62 (270)	7.33 (187)	45.80 (1164)	347 (158)		
CRN 45-2	15	3	29.49 (750)	12.36 (314)	8.00 (204)	48.03 (1220)	10.62 (270)	7.33 (187)	45.80 (1164)	347 (158)		
CRN 45-3-2	20	3	32.64 (830)	12.36 (314)	8.00 (204)	51.18 (1300)	11.50 (293)	8.92 (227)	52.33 (1330)	361 (164)		
CRN 45-3-1	25	3	32.64 (830)	12.36 (314)	8.00 (204)	55.03 (1398)	11.50 (293)	8.94 (228)	53.45 (1358)	353 (161)		
CRN 45-3	25	3	32.64 (830)	12.36 (314)	8.00 (204)	55.03 (1398)	11.50 (293)	8.94 (228)	53.45 (1358)	353 (161)		
CRN 45-4-2	30	3	35.79 (910)	12.36 (314)	8.00 (204)	58.18 (1478)	11.50 (293)	8.94 (228)	57.60 (1464)	427 (194)		
CRN 45-4-1	30	3	35.79 (910)	12.36 (314)	8.00 (204)	58.18 (1478)	11.50 (293)	8.94 (228)	57.60 (1464)	430 (196)		
CRN 45-4	30	3	35.79 (910)	12.36 (314)	8.00 (204)	58.18 (1478)	11.50 (293)	8.94 (228)	57.60 (1464)	430 (196)		
CRN 45-5-2	40	3	38.94 (990)	15.32 (390)	13.11 (333)	62.13 (1579)	13.25 (337)	12.21 (311)	62.19 (1580)	632 (287)		
CRN 45-5-1	40	3	38.94 (990)	15.32 (390)	13.11 (333)	62.13 (1579)	13.25 (337)	12.21 (311)	62.19 (1580)	632 (287)		
CRN 45-5	40	3	38.94 (990)	15.32 (390)	13.11 (333)	62.13 (1579)	13.25 (337)	12.21 (311)	62.19 (1580)	632 (287)		
CRN 45-6-2	50	3	42.09 (1070)	16.88 (429)	14.12 (359)	69.90 (1776)	13.25 (337)	12.21 (311)	64.84 (1647)	677 (308)		
CRN 45-6	50	3	42.09 (1070)	16.88 (429)	14.12 (359)	69.90 (1776)	13.25 (337)	12.21 (311)	64.84 (1647)	677 (308)		
CRN 45-7-2	50	3	45.24 (1150)	16.88 (429)	14.12 (359)	73.05 (1856)	13.25 (337)	12.21 (311)	67.99 (1727)	687 (312)		
CRN 45-7	60	3	45.24 (1150)	19.00 (483)	14.90 (379)	76.03 (1932)	15.12 (385)	13.19 (336)	71.37 (1813)	867 (394)		
CRN 45-8-1	60	3	48.39 (1230)	19.00 (483)	14.90 (379)	79.18 (2012)	15.12 (385)	13.19 (336)	74.52 (1893)	876 (398)		

¹⁾ Weights are based on pump with TEFC motor (see price list for individual weights). All dimensions in inches unless otherwise noted.

CR 64

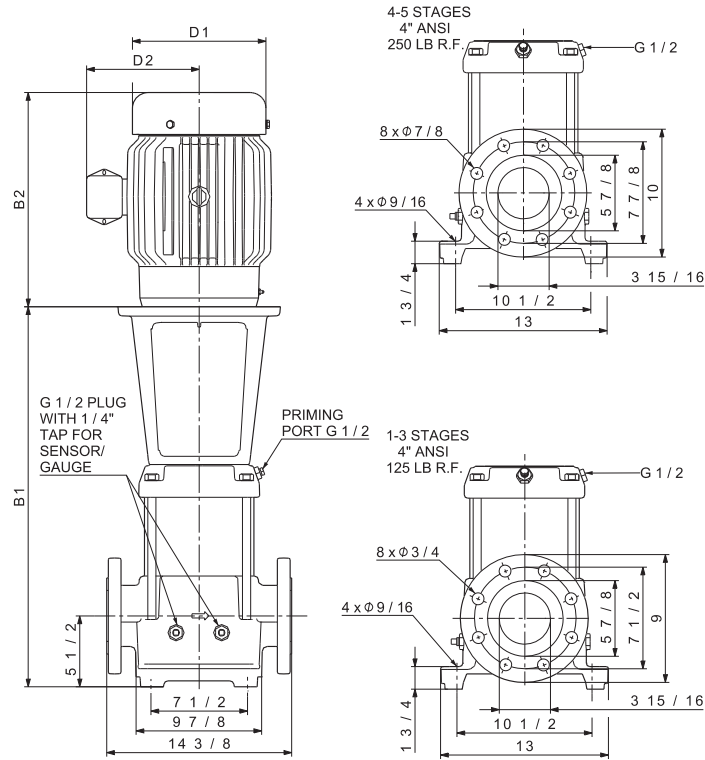

TM02 7701 1009

Pump type	P2 [Hp]	Ph.	ANSI dimensions [inch (mm)]								
			B1	TEFC			ODP			Ship. wt. ¹⁾ [lbs (kg)]	
				D1	D2	B1+B2	D1	D2	B1+B2		
CR 64-1-1	10	1	22.09 (562)	10.23 (260)	10.30 (262)	38.16 (970)	-	-	-	268 (122)	
		3	22.09 (562)	10.24 (261)	6.26 (160)	36.82 (936)	-	-	-	252 (115)	
CR 64-1	15	3	26.42 (672)	12.36 (314)	8.00 (204)	44.96 (1142)	10.62 (270)	7.33 (187)	42.73 (1086)	348 (158)	
CR 64-2-2	20	3	29.69 (755)	12.36 (314)	8.00 (204)	48.23 (1226)	11.50 (293)	8.92 (227)	49.38 (1255)	363 (165)	
CR 64-2-1	20	3	29.69 (755)	12.36 (314)	8.00 (204)	48.23 (1226)	11.50 (293)	8.92 (227)	49.38 (1255)	363 (165)	
CR 64-2	25	3	29.69 (755)	12.36 (314)	8.00 (204)	52.08 (1323)	11.50 (293)	8.94 (228)	50.50 (1283)	355 (162)	
CR 64-3-2	30	3	32.91 (836)	12.36 (314)	8.00 (204)	55.30 (1405)	11.50 (293)	8.94 (228)	54.72 (1390)	430 (196)	
CR 64-3-1	40	3	32.91 (836)	15.32 (390)	13.11 (333)	56.10 (1425)	13.25 (337)	12.21 (311)	56.16 (1427)	624 (284)	
CR 64-3	40	3	32.91 (836)	15.32 (390)	13.11 (333)	56.10 (1425)	13.25 (337)	12.21 (311)	56.16 (1427)	624 (284)	
CR 64-4-2	40	3	36.18 (919)	15.32 (390)	13.11 (333)	59.37 (1508)	13.25 (337)	12.21 (311)	59.43 (1510)	624 (284)	
CR 64-4-1	50	3	36.18 (919)	16.88 (429)	14.12 (359)	63.99 (1626)	13.25 (337)	12.21 (311)	58.93 (1497)	676 (307)	
CR 64-4	50	3	36.18 (919)	16.88 (429)	14.12 (359)	63.99 (1626)	13.25 (337)	12.21 (311)	58.93 (1497)	676 (307)	
CR 64-5-2	60	3	39.41 (1002)	19.00 (483)	14.90 (379)	70.20 (1784)	15.12 (385)	13.19 (336)	65.54 (1665)	866 (393)	

¹⁾ Weights are based on pump with TEFC motor (see price list for individual weights). All dimensions in inches unless otherwise noted.

CRN 64

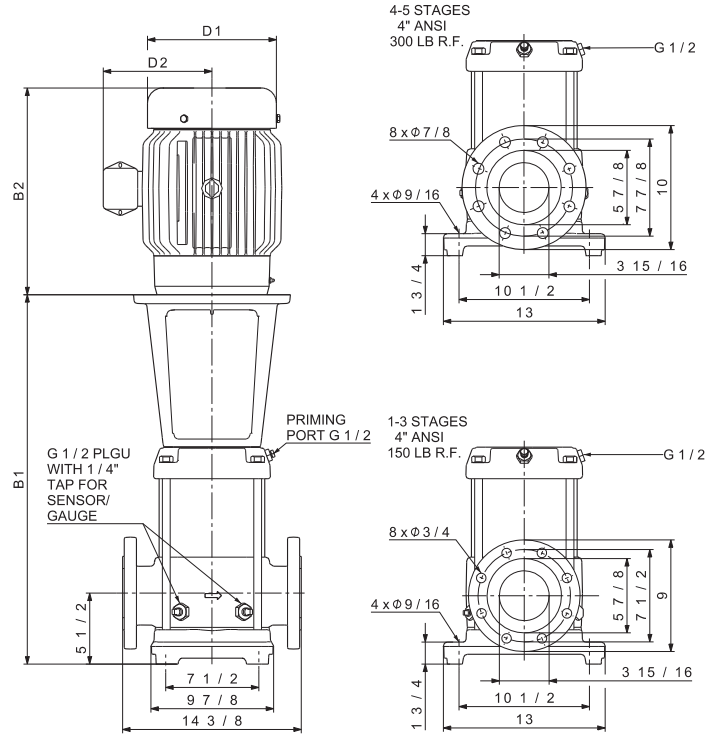

TM02 7705 1009

Pump type	P2 [Hp]	Ph.	ANSI dimensions [inch (mm)]							Ship. wt. ¹⁾ [lbs (kg)]
			B1	TEFC			ODP			
				D1	D2	B1+B2	D1	D2	B1+B2	
CRN 64-1-1	10	1	22.09 (562)	10.23 (260)	10.30 (262)	38.16 (970)	-	-	-	269 (123)
		3	22.09 (562)	10.24 (261)	6.26 (160)	36.82 (936)	-	-	-	253 (115)
CRN 64-1	15	3	26.42 (672)	12.36 (314)	8.00 (204)	44.96 (1142)	10.62 (270)	7.33 (187)	42.73 (1086)	349 (159)
CRN 64-2-2	20	3	29.69 (755)	12.36 (314)	8.00 (204)	48.23 (1226)	11.50 (293)	8.92 (227)	49.38 (1255)	364 (166)
CRN 64-2-1	20	3	29.69 (755)	12.36 (314)	8.00 (204)	48.23 (1226)	11.50 (293)	8.92 (227)	49.38 (1255)	364 (166)
CRN 64-2	25	3	29.69 (755)	12.36 (314)	8.00 (204)	52.08 (1323)	11.50 (293)	8.94 (228)	50.50 (1283)	357 (162)
CRN 64-3-2	30	3	32.91 (836)	12.36 (314)	8.00 (204)	55.30 (1405)	11.50 (293)	8.94 (228)	54.72 (1390)	432 (196)
CRN 64-3-1	40	3	32.91 (836)	15.32 (390)	13.11 (333)	56.10 (1425)	13.25 (337)	12.21 (311)	56.16 (1427)	625 (284)
CRN 64-3	40	3	32.91 (836)	15.32 (390)	13.11 (333)	56.10 (1425)	13.25 (337)	12.21 (311)	56.16 (1427)	625 (284)
CRN 64-4-2	40	3	36.18 (919)	15.32 (390)	13.11 (333)	59.37 (1508)	13.25 (337)	12.21 (311)	59.43 (1510)	625 (284)
CRN 64-4-1	50	3	36.18 (919)	16.88 (429)	14.12 (359)	63.99 (1626)	13.25 (337)	12.21 (311)	58.93 (1497)	678 (308)
CRN 64-4	50	3	36.18 (919)	16.88 (429)	14.12 (359)	63.99 (1626)	13.25 (337)	12.21 (311)	58.93 (1497)	678 (308)
CRN 64-5-2	60	3	39.41 (1002)	19.00 (483)	14.90 (379)	70.20 (1784)	15.12 (385)	13.19 (336)	65.54 (1665)	868 (394)

¹⁾ Weights are based on pump with TEFC motor (see price list for individual weights).
All dimensions in inches unless otherwise noted.

CR 90

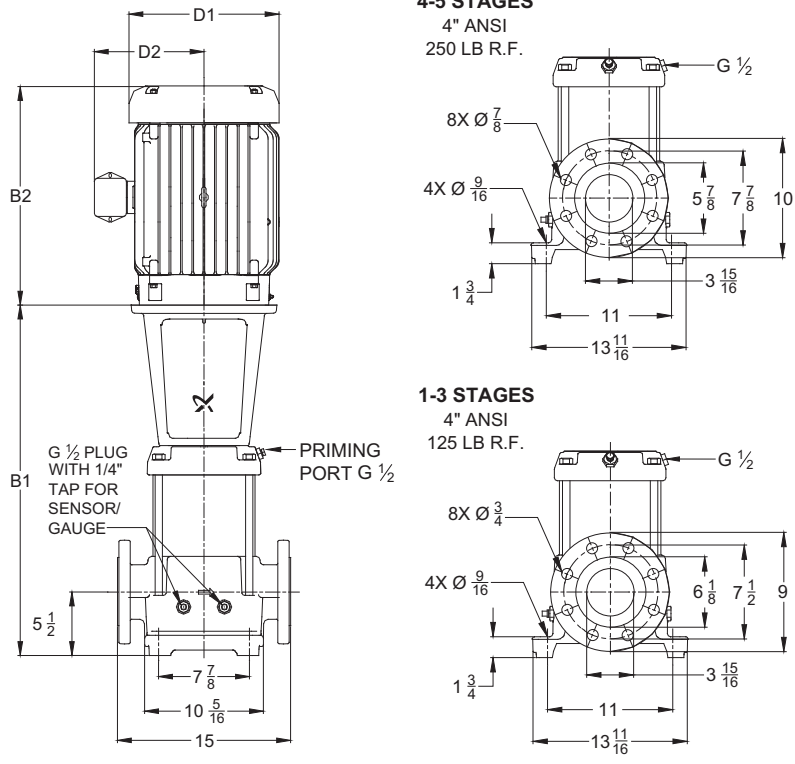

TM02 7702 3804

Pump type	P2 [Hp]	Ph.	ANSI dimensions [inch (mm)]									Ship. wt. ¹⁾ [lbs (kg)]
			B1	TEFC			ODP					
				D1	D2	B1+B2	D1	D2	B1+B2			
CR 90-1-1	15	3	26.81 (681)	12.36 (314)	8.00 (204)	45.35 (1152)	10.62 (270)	7.33 (187)	43.12 (1096)	358 (163)		
CR 90-1	20	3	26.81 (681)	12.36 (314)	8.00 (204)	45.35 (1152)	11.50 (293)	8.92 (227)	46.50 (1182)	363 (165)		
CR 90-2-2	25	3	30.43 (773)	12.36 (314)	8.00 (204)	52.82 (1342)	11.50 (293)	8.94 (228)	51.24 (1302)	367 (167)		
CR 90-2-1	30	3	30.43 (773)	12.36 (314)	8.00 (204)	52.82 (1342)	11.50 (293)	8.94 (228)	52.24 (1327)	432 (196)		
CR 90-2	40	3	30.43 (773)	15.32 (390)	13.11 (333)	53.62 (1362)	13.25 (337)	12.21 (311)	53.68 (1364)	625 (284)		
CR 90-3-2	40	3	34.06 (866)	15.32 (390)	13.11 (333)	57.25 (1455)	13.25 (337)	12.21 (311)	57.31 (1456)	636 (289)		
CR 90-3-1	50	3	34.06 (866)	16.88 (429)	14.12 (359)	61.87 (1572)	13.25 (337)	12.21 (311)	56.81 (1443)	667 (303)		
CR 90-3	50	3	34.06 (866)	16.88 (429)	14.12 (359)	61.87 (1572)	13.25 (337)	12.21 (311)	56.81 (1443)	667 (303)		
CR 90-4-2	60	3	37.68 (958)	19.00 (483)	14.90 (379)	68.47 (1740)	15.12 (385)	13.19 (336)	63.81 (1621)	869 (395)		
CR 90-4-1	60	3	37.68 (958)	19.00 (483)	14.90 (379)	68.47 (1740)	15.12 (385)	13.19 (336)	63.81 (1621)	869 (395)		

¹⁾ Weights are based on pump with TEFC motor (see price list for individual weights). All dimensions in inches unless otherwise noted.

CRN 90

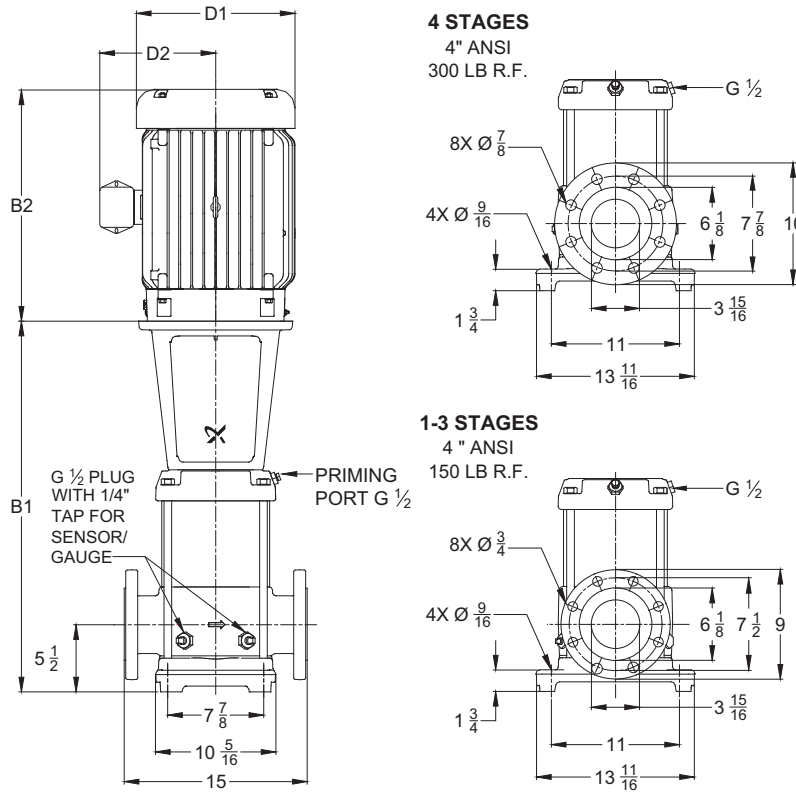

TM02 7706 3804

Pump type	P2 [Hp]	Ph.	ANSI dimensions [inch (mm)]									Ship. wt. ¹⁾ [lbs (kg)]
			B1	TEFC			ODP					
				D1	D2	B1+B2	D1	D2	B1+B2			
CRN 90-1-1	15	3	26.81 (681)	12.36 (314)	8.00 (204)	45.35 (1152)	10.62 (270)	7.33 (187)	43.12 (1096)	364 (166)		
CRN 90-1	20	3	26.81 (681)	12.36 (314)	8.00 (204)	45.35 (1152)	11.50 (293)	8.92 (227)	46.50 (1182)	369 (168)		
CRN 90-2-2	25	3	30.43 (773)	12.36 (314)	8.00 (204)	52.82 (1342)	11.50 (293)	8.94 (228)	51.24 (1302)	372 (169)		
CRN 90-2-1	30	3	30.43 (773)	12.36 (314)	8.00 (204)	52.82 (1342)	11.50 (293)	8.94 (228)	52.24 (1327)	450 (205)		
CRN 90-2	40	3	30.43 (773)	15.32 (390)	13.11 (333)	53.62 (1362)	13.25 (337)	12.21 (311)	53.68 (1364)	631 (287)		
CRN 90-3-2	40	3	34.06 (866)	15.32 (390)	13.11 (333)	57.25 (1455)	13.25 (337)	12.21 (311)	57.31 (1456)	642 (292)		
CRN 90-3-1	50	3	34.06 (866)	16.88 (429)	14.12 (359)	61.87 (1572)	13.25 (337)	12.21 (311)	56.81 (1443)	668 (304)		
CRN 90-3	50	3	34.06 (866)	16.88 (429)	14.12 (359)	61.87 (1572)	13.25 (337)	12.21 (311)	56.81 (1443)	672 (305)		
CRN 90-4-2	60	3	37.68 (958)	19.00 (483)	14.90 (379)	68.47 (1740)	15.12 (385)	13.19 (336)	63.81 (1621)	876 (398)		
CRN 90-4-1	60	3	37.68 (958)	19.00 (483)	14.90 (379)	68.47 (1740)	15.12 (385)	13.19 (336)	63.81 (1621)	876 (398)		

¹⁾ Weights are based on pump with TEFC motor (see price list for individual weights). All dimensions in inches unless otherwise noted.

CR 120

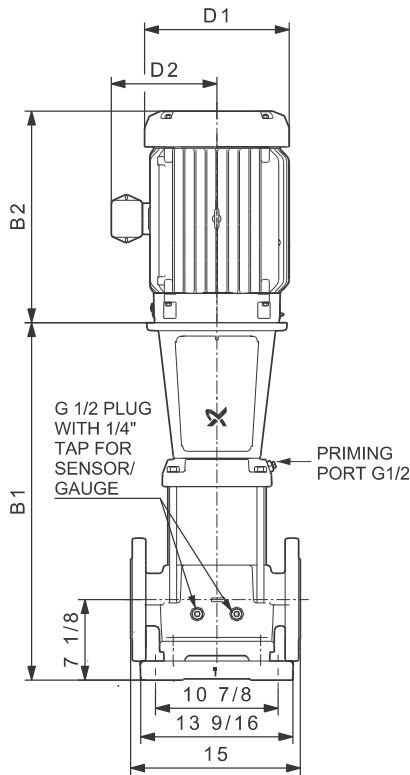

1-1 to 4-2 STAGES
5" FLANGE²⁾

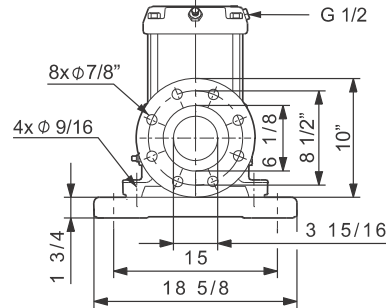

4-1 to 5-1 STAGES
5" FLANGE²⁾

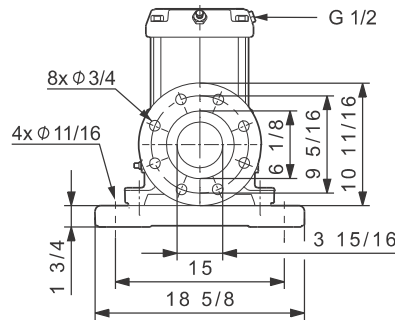

TM04 9630 4810

Pump type	P2 [Hp]	Ph.	ANSI dimensions [inch (mm)]									Ship. wt. ¹⁾ [lbs (kg)]
			B1	TEFC			ODP					
				D1	D2	B1+B2	D1	D2	B1+B2			
CR 120-1-1	20	3	32.83 (834)	12.36 (314)	8.00 (204)	51.37 (1305)	11.50 (293)	8.92 (227)	52.52 (1335)	432 (196)		
CR 120-1	25	3	32.83 (834)	12.36 (314)	8.00 (204)	55.22 (1403)	11.50 (293)	8.94 (228)	53.64 (1363)	424 (110)		
CR 120-2-2	40	3	38.98 (991)	15.32 (390)	13.11 (333)	62.17 (1580)	13.25 (337)	12.21 (311)	62.23 (1581)	704 (320)		
CR 120-2-1	40	3	38.98 (991)	15.32 (390)	13.11 (333)	62.17 (1580)	13.25 (337)	12.21 (311)	62.23 (1581)	704 (320)		
CR 120-2	50	3	38.98 (991)	16.88 (429)	14.12 (359)	66.79 (1697)	13.25 (337)	12.21 (311)	61.73 (1568)	735 (334)		
CR 120-3-2	60	3	45.08 (1146)	19.00 (483)	14.90 (379)	75.87 (1928)	15.12 (385)	13.19 (336)	71.21 (1809)	936 (425)		
CR 120-3-1	60	3	45.08 (1146)	19.00 (483)	14.90 (379)	75.87 (1928)	15.12 (385)	13.19 (336)	71.21 (1809)	936 (425)		
CR 120-3	75	3	45.08 (1146)	19.00 (483)	14.90 (379)	75.87 (1928)	15.18 (386)	13.19 (336)	71.21 (1809)	1045 (475)		
CR 120-4-2	75	3	51.69 (1313)	19.00 (483)	14.90 (379)	82.48 (2095)	15.18 (386)	13.19 (336)	77.82 (1977)	1199 (544)		
CR 120-4-1	100	3	51.69 (1313)	19.00 (483)	17.38 (442)	82.51 (2096)	15.12 (385)	13.19 (336)	79.07 (2009)	1468 (666)		
CR 120-4	100	3	51.69 (1313)	19.00 (483)	17.38 (442)	82.51 (2096)	15.12 (385)	13.19 (336)	79.07 (2009)	1468 (666)		
CR 120-5-2	100	3	57.80 (1469)	19.00 (483)	17.38 (442)	88.62 (2251)	15.12 (385)	13.19 (336)	85.18 (2164)	1490 (676)		
CR 120-5-1 ³⁾	125	3	57.80 (1469)	-	-	-	16.81 (427)	16.39 (417)	88.77 (2255)	1191 (541)		

1) Weights are based on pump with TEFC motor (see price list for individual weights).
 2) This is a 5" loose flange ring. When using a 5" mating flange, the gasket contact surface is reduced to approximately 0.25". A 4" loose flange ring is available for 4" pipe work. This will provide a standard gasket contact surface. Also available is a 6" ANSI flange adapter manufactured to ANSI B16.5 specifications.
 3) CR 120-5-1, 125 Hp, ODP motor only.
 All dimensions in inches unless otherwise noted.

CRN 120

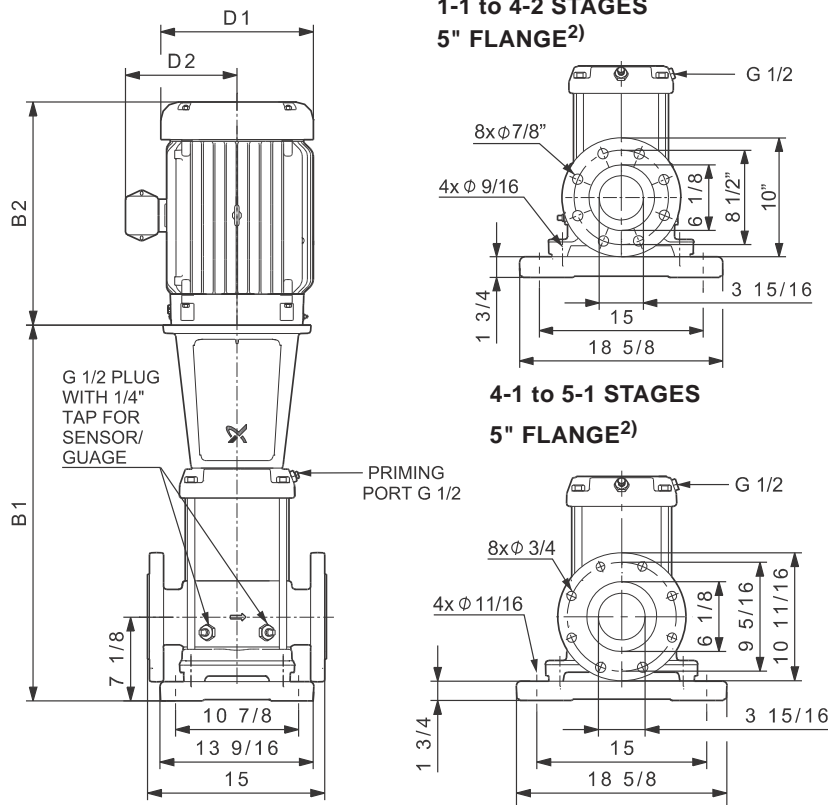

TM04 9631 4810

Pump type	P2 [Hp]	Ph.	ANSI dimensions [inch (mm)]									Ship. wt. ¹⁾ [lbs (kg)]
			B1	TEFC			ODP					
				D1	D2	B1+B2	D1	D2	B1+B2			
CRN 120-1-1	20	3	32.83 (834)	12.36 (314)	8.00 (204)	51.37 (1305)	11.50 (293)	8.92 (227)	52.52 (1335)	439 (200)		
CRN 120-1	25	3	32.83 (834)	12.36 (314)	8.00 (204)	55.22 (1403)	11.50 (293)	8.94 (228)	53.64 (1363)	431 (196)		
CRN 120-2-2	40	3	38.98 (991)	15.32 (390)	13.11 (333)	62.17 (1580)	13.25 (337)	12.21 (311)	62.23 (1581)	711 (323)		
CRN 120-2-1	40	3	38.98 (991)	15.32 (390)	13.11 (333)	62.17 (1580)	13.25 (337)	12.21 (311)	62.23 (1581)	711 (323)		
CRN 120-2	50	3	38.98 (991)	16.88 (429)	14.12 (359)	66.79 (1697)	13.25 (337)	12.21 (311)	61.73 (1568)	742 (337)		
CRN 120-3-2	60	3	45.08 (1146)	19.00 (483)	14.90 (379)	75.87 (1928)	15.12 (385)	13.19 (336)	71.21 (1809)	943 (428)		
CRN 120-3-1	60	3	45.08 (1146)	19.00 (483)	14.90 (379)	75.87 (1928)	15.12 (385)	13.19 (336)	71.21 (1809)	943 (428)		
CRN 120-3	75	3	45.08 (1146)	19.00 (483)	14.90 (379)	75.87 (1928)	15.18 (386)	13.19 (336)	71.21 (1809)	1052 (478)		
CRN 120-4-2	75	3	51.69 (1313)	19.00 (483)	14.90 (379)	82.48 (2095)	15.18 (386)	13.19 (336)	77.82 (1977)	1206 (548)		
CRN 120-4-1	100	3	51.69 (1313)	19.00 (483)	17.38 (442)	82.51 (2096)	15.12 (385)	13.19 (336)	79.07 (2009)	1475 (670)		
CRN 120-4	100	3	51.69 (1313)	19.00 (483)	17.38 (442)	82.51 (2096)	15.12 (385)	13.19 (336)	79.07 (2009)	1475 (670)		
CRN 120-5-2	100	3	57.80 (1469)	19.00 (483)	17.38 (442)	88.62 (2251)	15.12 (385)	13.19 (336)	85.18 (2164)	1497 (680)		
CRN 120-5-1 ³⁾	125	3	57.80 (1469)	-	-	-	16.81 (427)	16.39 (417)	88.77 (2255)	1200 (545)		

1) Weights are based on pump with TEFC motor (see price list for individual weights).
 2) This is a 5" loose flange ring. When using a 5" mating flange, the gasket contact surface is reduced to approximately 0.25". A 4" loose flange ring is available for 4" pipe work. This will provide a standard gasket contact surface. Also available is a 6" ANSI flange adapter manufactured to ANSI B16.5 specifications.
 3) CRN 120-5-1, 125 Hp, ODP motor only.
 All dimensions in inches unless otherwise noted.

CR 150

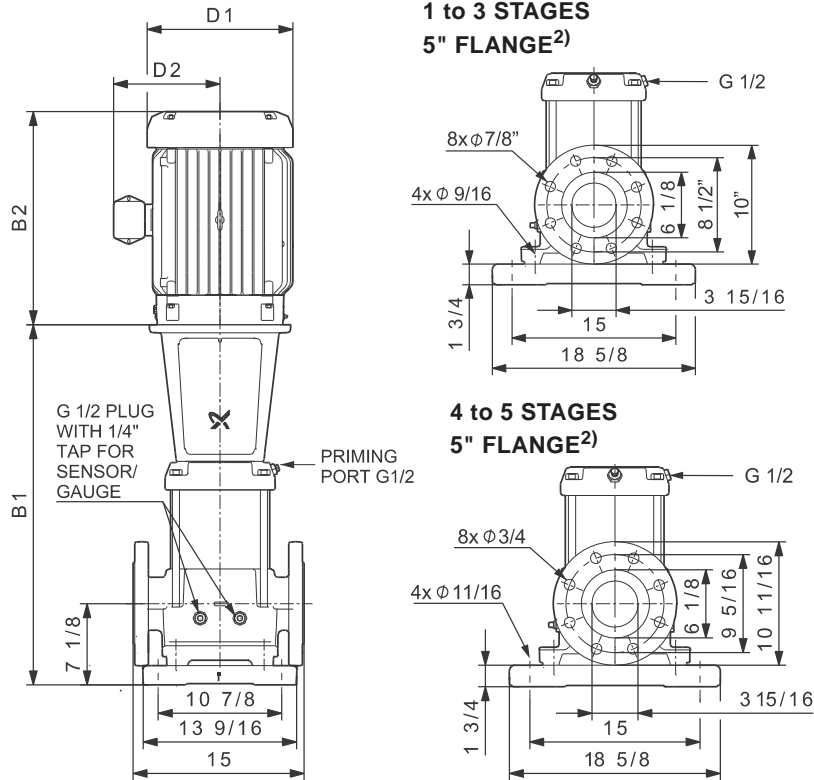

TM04 9632 4810

Pump type	P2 [Hp]	Ph.	ANSI dimensions [inch (mm)]									Ship. wt. ¹⁾ [lbs (kg)]
			B1	TEFC			ODP					
				D1	D2	B1+B2	D1	D2	B1+B2			
CR 150-1-1	25	3	32.83 (834)	12.36 (314)	8.00 (204)	55.22 (1403)	11.50 (293)	8.94 (228)	53.64 (1363)	424 (193)		
CR 150-1	30	3	32.83 (834)	12.36 (314)	8.00 (204)	55.22 (1403)	11.50 (293)	8.94 (228)	54.64 (1388)	490 (223)		
CR 150-2-2	40	3	38.98 (991)	15.32 (390)	13.11 (333)	62.17 (1580)	13.25 (337)	12.21 (311)	62.23 (1581)	705 (320)		
CR 150-2-1	50	3	38.98 (991)	16.88 (429)	14.12 (359)	66.79 (1697)	13.25 (337)	12.21 (311)	61.73 (1568)	735 (334)		
CR 150-2	60	3	38.98 (991)	19.00 (483)	14.90 (379)	69.77 (1773)	15.12 (385)	13.19 (336)	65.11 (1654)	915 (416)		
CR 150-3-2	75	3	45.55 (1157)	19.00 (483)	14.90 (379)	76.34 (1940)	15.18 (386)	13.19 (336)	71.68 (1821)	1178 (535)		
CR 150-3-1	75	3	45.55 (1157)	19.00 (483)	14.90 (379)	76.34 (1940)	15.18 (386)	13.19 (336)	71.68 (1821)	1178 (535)		
CR 150-3	100	3	45.55 (1157)	19.00 (483)	17.38 (442)	76.37 (1940)	15.12 (385)	13.19 (336)	72.93 (1853)	1215 (552)		
CR 150-4-2	100	3	51.69 (1313)	19.00 (483)	17.38 (442)	82.51 (2096)	15.12 (385)	13.19 (336)	79.07 (2009)	1234 (560)		
CR 150-4-1	100	3	51.69 (1313)	19.00 (483)	17.38 (442)	82.51 (2096)	15.12 (385)	13.19 (336)	79.07 (2009)	1234 (560)		

1) Weights are based on pump with TEFC motor (see price list for individual weights).
 2) This is a 5" loose flange ring. When using a 5" mating flange, the gasket contact surface is reduced to approximately 0.25". A 4" loose flange ring is available for 4" pipe work. This will provide a standard gasket contact surface. Also available is a 6" ANSI flange adapter manufactured to ANSI B16.5 specifications.
 All dimensions in inches unless otherwise noted.

CRN 150

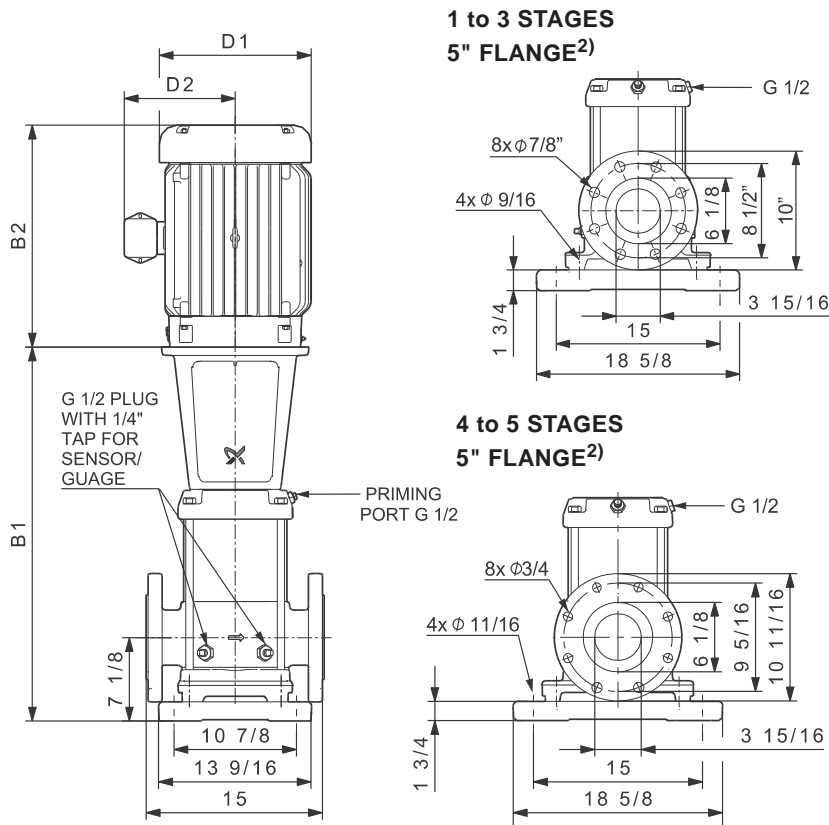

TM04 9633 4810

Pump type	P2 [Hp]	Ph.	ANSI dimensions [inch (mm)]									Ship. wt. ¹⁾ [lbs (kg)]
			B1	TEFC			ODP					
				D1	D2	B1+B2	D1	D2	B1+B2			
CRN 150-1-1	25	3	32.83 (834)	12.36 (314)	8.00 (204)	55.22 (1403)	11.50 (293)	8.94 (228)	53.64 (1363)	431 (196)		
CRN 150-1	30	3	32.83 (834)	12.36 (314)	8.00 (204)	55.22 (1403)	11.50 (293)	8.94 (228)	54.64 (1388)	496 (225)		
CRN 150-2-2	40	3	38.98 (991)	15.32 (390)	13.11 (333)	62.17 (1580)	13.25 (337)	12.21 (311)	62.23 (1581)	711 (323)		
CRN 150-2-1	50	3	38.98 (991)	16.88 (429)	14.12 (359)	66.79 (1697)	13.25 (337)	12.21 (311)	61.73 (1568)	741 (337)		
CRN 150-2	60	3	38.98 (991)	19.00 (483)	14.90 (379)	69.77 (1773)	15.12 (385)	13.19 (336)	65.11 (1654)	922 (419)		
CRN 150-3-2	75	3	45.55 (1157)	19.00 (483)	14.90 (379)	76.34 (1940)	15.18 (386)	13.19 (336)	71.68 (1821)	1184 (538)		
CRN 150-3-1	75	3	45.55 (1157)	19.00 (483)	14.90 (379)	76.34 (1940)	15.18 (386)	13.19 (336)	71.68 (1821)	1184 (538)		
CRN 150-3	100	3	45.55 (1157)	19.00 (483)	17.38 (442)	76.37 (1940)	15.12 (385)	13.19 (336)	72.93 (1853)	1222 (555)		
CRN 150-4-2	100	3	51.69 (1313)	19.00 (483)	17.38 (442)	82.51 (2096)	15.12 (385)	13.19 (336)	79.07 (2009)	1243 (564)		
CRN 150-4-1	100	3	51.69 (1313)	19.00 (483)	17.38 (442)	82.51 (2096)	15.12 (385)	13.19 (336)	79.07 (2009)	1243 (564)		

1) Weights are based on pump with TEFC motor (see price list for individual weights).

2) This is a 5" loose flange ring. When using a 5" mating flange, the gasket contact surface is reduced to approximately 0.25". A 4" loose flange ring is available for 4" pipe work. This will provide a standard gasket contact surface. Also available is a 6" ANSI flange adapter manufactured to ANSI B16.5 specifications.

All dimensions in inches unless otherwise noted.

11. Motor data

Standard motors in the CR range

Motors used in the CR pump range are:

- Grundfos ML motors
- Grundfos specified **Baldor®** motors.

The information in the tables below applies to following motors type and size:

Type	Phase	Motor range [Hp]	Cooling method
ML	3	1/3 - 30	TEFC
	1	1/3 - 10	TEFC
Baldor	3	40-100	TEFC
	3	15-125	ODP

Grundfos CR pumps are supplied with heavy-duty 2-pole, NEMA energy efficient C-frame motors built or selected to our rigid specifications. All CR pump motors have heavy-duty bearings for maximum thrust requirements.

ODP motors

(Open Drip Proof, constant speed)

Hp	Ph	ODP frame	ODP S.F.	ODP voltage [V]	ODP motor eff. %	ODP insul. class	ODP KVA code	ODP full load current	ODP service factor current	ODP starting current
15	3	254TCZ	1.15	208-230/460	89.5	F	H	37-35 / 17.5	40 - 39.4 / 19.7	225-248/124
20	3	254TC	1.15	230/460	90.2	B	G	48/24	55 /27.5	306/153
25	3	284TSCZ	1.15	208-230/460	91	B	G	64-59 / 29.5	74-67 / 33.5	335-374/187
30	3	284TSC	1.15	230/460	91	F	H	70/35	80/40	480/240
40	3	286TSCZ	1.15	230/460	91.7	F	F	94/47	108/54	542/271
50	3	324TSCZ	1.15	230/460	92.4	F	G	116/58	134/67	706/353
60	3	324TSCZ	1.15	230/460	93	B	G	132/66	152/76	844/422
75	3	364TSCZ	1.15	230/460	93	F	G	168/84	192/96	1110/555
100	3	365TSCZ	1.15	230/460	93	F	G	226/113	260/130	1380/690
125	3	405TSCZ	1.15	460	93.6	B	G	140	171	897

Baldor motor



TM02 7696 3803

It is not recommended that an off-the-shelf standard Baldor motor be used on a Grundfos pump. Ideally, the best motor choice would be the Grundfos specified motor.

Single-phase Grundfos specified motors up to 7.5 Hp have a built-in thermal overload switch.

Other motor types are available (i.e., Explosion proof, Mill and Chem duty, Premium Efficiency, etc.); consult local Grundfos company for more information.

Pumps supplied by Grundfos Canada are normally supplied with motors from other manufactures. 575 volt motors meet NEMA energy efficient standards.

Dimensions and data will vary, contact local Grundfos company for more information.

All values are subject to change without notice.

TEFC motors

(Totally Enclosed Fan Cooled, constant speed)

Baldor motor



TM02 7696 3803

Grundfos ML motors



Gr7848sh



GR 7845



TM04 2512 2708

Hp	Ph	Frame	S.F.	Voltage [V]	Motor eff. [%]	Insul. class	KVA code	Full load current [A]	Service factor current [A]	Starting current [A]	Motor type
1/3	1	56C	1.35	115/230	55	B	K	6.0 / 3.0	7.6 / 3.8	28 / 14	Baldor
	3	56C	1.35	208-230/460	78.5	F	L	1.12 - 1.1 / 0.55	1.5 - 1.45 / 0.75	7.1 - 7.7 / 3.9	ML
1/2	1	56C	1.6	115/230	62	B	K	7.4 / 3.7	9.8 / 4.9	39 / 19.5	Baldor
	3	56C	1.25	208-230/460	78.5	F	K	1.64 - 1.55 / 0.78	2.0 - 1.9 / 0.95	9.7 - 10.1 / 5.1	ML
3/4	1	56C	1.25	115/230	66	B	K	9.6 / 4.8	11.4 / 5.7	56/28	Baldor
	3	56C	1.25	208-230/460	79	F	K	2.4 - 2.3 / 1.2	2.9 - 2.75 / 1.4	14.2 - 15 / 7.8	ML
1	1	56C	1.25	115/230	66	B	K	12 / 6.0	14.4 / 7.2	77 / 38.5	Baldor
	3	56C	1.25	208-230/460	80	F	J	3.25 - 3.35 / 1.68	4.0 - 3.9 / 1.95	19.2 - 21.8 / 10.9	ML
1 1/2	1	56C	1.3	115/208-230	71	B	K	17 / 9.5 - 8.6	20.4 / 11.3 - 10.2	106 / 58.6 - 53	Baldor
	3	56C	1.15	208-230/460	84	F	M	4.7 - 4.6 / 2.3	5.2 - 5.1 / 2.55	33.8 - 36.8 / 18.4	ML
2	1	56C	1.15	115/208-230	74	F	K	23 / 12.7 - 11.5	25.4 / 14.0 - 12.7	156/86-78	Baldor
	3	56C	1.15	208-230/460	85.5	F	G	5.7 - 5.4 / 2.7	6.55 - 6.1 / 3.05	46.2 - 48.6 / 24.3	ML
3	1	182TC	1.15	115/208-230	75	F	H	29 / 16 - 14.5	31.8 / 18 - 15.9	170/94-85	Baldor
	3	182TC	1.15	208-230/460	86.5	F	M	8.35 - 7.50 / 3.75	9.10 - 8.15 / 4.10	86.8 - 78.0 / 39.0	ML
5	1	213TCZ	1.15	208-230	80	F	J	24-22	27-25	188-170	Baldor
	3	182TC	1.15	208-230/460	88.5	F	L	14.1 - 13.1 / 7.29	16.2 - 15.0 / 8.4	207-193/107	ML
7 1/2	1	213TC	1.15	208-230	82	F	F	33.8-31	38.5-35.5	244-220	Baldor
	3	213TC	1.15	208-230/460	89.5	F	N	19.5 - 18.1 / 9.09	22.4 - 20.8 / 10.4	289-267/135	ML
10	1	213TC	1.15	230	85.5	F	F	40	46	284	Baldor
	3	215TC	1.15	208-230/460	90.2	F	K	26.5 - 24.6 / 12.4	29.0 - 27.0 / 13.6	261-243/123	ML
15	3	254TC	1.15	208-230/460	91	F	J	37.5 - 34 / 17	41.0 - 37.5 / 18.6	369-338/168	ML
20	3	254TC	1.15	208-230/460	91	F	K	50.5 - 46 / 23	55.5 - 50.5 / 25.5	450-410/207	ML
25	3	284TSC	1.15	230/460	91.7	F	J	62.0 - 56 / 28	68.0 - 61.5 / 31.0	510-462/233	ML
30	3	286TSC	1.15	230/460	91.7	F	H	74.0 - 67.0 / 33.5	81.5 - 73.5 / 37.0	595-537/271	ML
40	3	286TSC	1.15	230/460	91.7	F	G	88/44	102/51	614/307	Baldor
50	3	326TSCZ	1.15	230/460	93	F	G	110/55	128/64	746/393	Baldor
60	3	364TSCZ	1.15	230/460	93	F	G	134/67	154/77	918/459	Baldor
75	3	365TSCZ	1.15	230/460	93	F	G	166/83	188/94	1162/581	Baldor
100	3	405TSCZ	1.15	230/460	93.6	F	G	216/108	246/123	1422/711	Baldor

12. Accessories

Pipework connections

For pipework connection, various sets of counter flanges and couplings are available.

Adapter kit

6" flanges are available for CR, CRN 120 and 150 pumps. To use 6" flanges, two adapter kits must be ordered per pump.

Adapter kit	Pump type	Pipe connection	Number of flange kits needed	Product number
	CR 120 CR 150	6" RF 250 lb. Ductile iron	2	96638184
	CRN 120 CRN 150	6" RF 300 lb. ANSI 316 SS	2	96638186

Counter flanges for CR

A set consists of two counter flanges, two gaskets, bolts and nuts.

Counter flange	Pump type	Description	Pressure class	Pipework connection	Product number
	TM02 5691 3802	CR 1s CR 1 CR 3 CR 5	Threaded	ANSI 250 lb.	1 1/4" NPT 91122260
	TM02 5692 3802	CR 10 CR 15 CR 20	Threaded	ANSI 250 lb.	2" NPT 335021
	TM02 5693 3802 TM02 5694 3802	CR 32	Threaded	ANSI 125 lb.	2 1/2" NPT 559601
	TM02 5695 3802 TM02 5696 3802	CR 45	Threaded	ANSI 125 lb.	3" NPT 569601
	TM02 5695 3802 TM02 5696 3802	CR 45	Threaded	ANSI 250 lb.	3" NPT 91121952

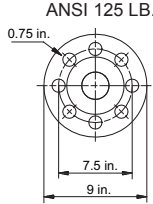
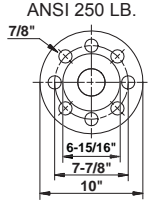
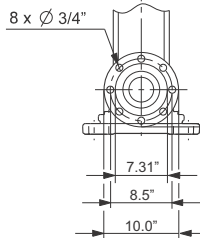
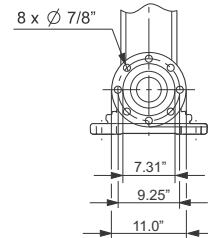
Counter flange	Pump type	Description	Pressure class	Pipework connection	Product number
	TM02 5697 3802 TM02 5698 3802 CR 64 CR 90	Threaded	ANSI 125 lb.	4" NPT	579801
		Threaded	ANSI 250 lb.	4" NPT	3600028
	TM06 0509 1109 CR 120 CR 150	Threaded	ANSI 125 lb.	5" NPT	91121956
		Threaded	ANSI 250 lb.	5" NPT	91121957

Counter flanges for CRN

Counterflanges for CRN pumps are made of stainless steel according to AISI 316.

A set consists of two counter flanges, two gaskets, bolts and nuts.

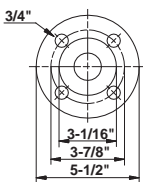
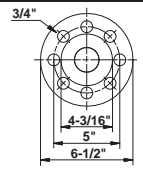
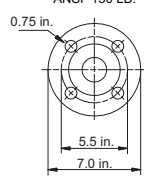
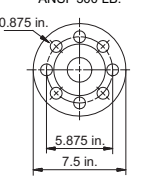
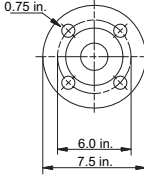
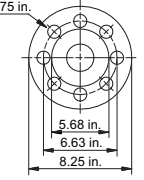
Counter flange	Pump type	Description	Pressure class	Pipework connection	Product number
	TM02 5691 3802 CRI, CRN 1s, 1, 3 and 5	Threaded	ANSI 300 lb.	1 1/4" NPT	91129013
		TM02 5692 3802 CRI, CRN 10, 15, 20	Threaded	ANSI 300 lb.	2" NPT
	TM02 5693 3802 TM02 5694 3802 CRN 32	Threaded	ANSI 150 lb.	2 1/2" NPT	91121951
		Threaded	ANSI 300 lb.	2 1/2" NPT	0ID00138
	TM02 5695 3802 TM02 5696 3802 CRN 45	Threaded	ANSI 150 lb.	3" NPT	91121953
		Threaded	ANSI 300 lb.	3" NPT	91121954

Counter flange	Pump type	Description	Pressure class	Pipework connection	Product number
 ANSI 150 LB.	 ANSI 300 LB.	TM02 5697 3802 TM02 5698 3802	CRN 64 CRN 90	Threaded	ANSI 150 lb. 4" NPT 0ID00148
				Threaded	ANSI 300 lb. 4" NPT 91121955
 8 x Ø 3/4"	 8 x Ø 7/8"	TM06 0509 1109	CRN 120 CRN 150	Threaded	ANSI 150 lb. 5" NPT 91121958
				Threaded	ANSI 300 lb. 5" NPT 91121959

PJE couplings for CRN

Couplings for CRN pumps are made of stainless steel according to AISI 316.

A set consists of two couplings, two gaskets, two pipe stub and bolts and nuts.

Couplings	Pump type	Pipe stub	Rated pressure	Pipework connection	Rubber parts	Number of coupling sets needed	Product number
 TM00 3808 1094	CRI, CRN 1s, 1, 3 and 5	Threaded	1160 psi	1 1/4" NPT	EPDM	1	4013010
					FKM	1	0ID00118
	CRI CRN 10, 15 and 20	Threaded	1015 psi	2" NPT	EPDM	1	331301
					FKM	1	0ID00128

FlexiClamp base connections

All sets comprise the necessary number of bolts and nuts as well as a gasket/O-ring.

Base connections	Pump type	Connection	Pipework connection	Rubber parts	Product number
 TM02 1144 0601	CRI, CRN 1s, 1, 3 and 5	Oval (cast iron)	1" NPT	Klingsil	96468491
			1 1/4" NPT	Klingsil	96470781
		Oval (stainless steel)	1" NPT	Klingsil	96480850
			1 1/4" NPT	Klingsil	96480851
 TM02 1145 0601	CRI, CRN 1s, 1, 3 and 5	Union ext. threaded	2" NPT	EPDM	96480852
				FKM	96480853

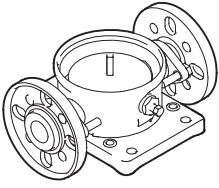
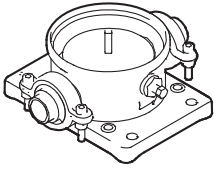
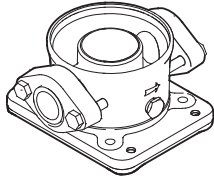
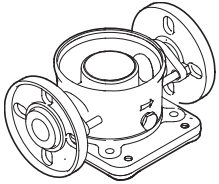
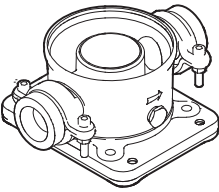
Base connections	Pump type	Connection	Pipework connection	Rubber parts	Product number
	CRI, CRN 1s, 1, 3 and 5	ANSI (FGJ) (stainless steel)	1 1/4" NPT	EPDM	96480858
				FKM	96480859
	CRI, CRN 1s, 1, 3 and 5	Clamp, threaded pipe stub	1" NPT	EPDM	96480854
				FKM	96480855
			1 1/4" NPT	EPDM	96480856
				FKM	96480857
	CRI, CRN 10, 15 and 20	Oval (cast iron)	2" NPT	Klingsil	96498838
		Oval (stainless steel)	2" NPT	Klingsil	96498839
	CRI, CRN 10, 15 and 20	ANSI (FGJ) (stainless steel)	2" NPT	EPDM	96511402
				FKM	96511403
	CRI, CRN 10, 15 and 20	Clamp, threaded pipe stub	1 1/2" NPT	EPDM	96500271
				FKM	96500272
			2" NPT	EPDM	96500273
				FKM	96500274
			2" NPT	EPDM	96508602
				FKM	96508603

CR flange guide

Commonly asked questions

What is the "pressure class"?

- The pressure class is a pressure rating expressed as a dimensionless number.
- Pressure class does not affect the pump working pressure.
- The class rating charts in ANSI B16.5 give actual pounds per square inch maximum allowable pressure at a given temperature.
- 150 lb, 150# or Class 150 are different ways to write the same pressure class.





What factors determine the required pressure class?

Pressure ratings are affected by:

- Material
- sealing methods
- operating temperatures.

Are pump flanges compatible with mating flanges of a different pressure class?

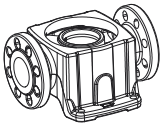
- The multiflange used on a CR 1s through 20 can be used on both 125 lb and 250 lb installations.
- The multiflange on a CRI/CRN 1s through 20 can be used on both 150 lb and 300 lb installations.
- All other mating flange classes must match the pump flange class.

Pump	Flange	Size	Material	Pressure class	Mate with:
CR 1s to 5		1.25 in	Cast Iron	250 lb	125 or 250 lb
CRI, CRN 1s to 5		1.25 in	Ductile Iron	300 lb	150 or 300 lb
CR 10 to 20		2 in	Cast Iron	250 lb	125 or 250 lb
CRI, CRN 10 to 20		2 in	Ductile Iron	300 lb	150 or 300 lb

13. Variants

Lists of variants - on request

Although the Grundfos CR, CRI, CRN product range offers a number of pumps for different applications, customers require specific pump solutions to satisfy their needs.

Below please find the range of options available for customizing the CR pumps to meet the customers' demands. Contact Grundfos for further information or for requests other than the ones mentioned below.

Motors

Variant	Description
Explosion proof motors	For operation in hazardous atmospheres, explosion-proof or dust-ignition-proof motors may be required.
Motors with anti-condensation heating unit	For operation in humid environments motors with built-in anti-condensation heating may be required.
Premium efficient motors	Grundfos offers motors from 1 to 100 Hp with a Premium efficiency class.
Different motor brand	If technically possible, Grundfos can fit the pump with a motor of a brand other than the standard. This will normally increase the time of delivery. Alternatively, the pump can be supplied without a motor (motor thrust rating must be checked).
Oversized motor	Ambient temperatures above 104 °F or installation at altitudes of more than 3280 ft above sea level require the use of an oversized motor (i.e. derating).
4-pole motors	Grundfos offers standard motors fitted with 4-poles.

Connections and other variants

Variant	Description
Pipe connections	In addition to the wide range of standard flange connections, a 232 psi DIN standard clamping flange is available. Customized flanges are available according to specifications.
TriClamp connections	TriClamp connections are of a hygienic design with a sanitary coupling for use in the pharmaceutical and food industry.
Electropolished pumps	To substantially reduce the risk of corrosion of the materials. For use in the pharmaceutical/food industry.

Shaft seals

Variant	Description
Shaft seal with FFKM O-ring material	Shaft seals with FFKM or FXM o-ring material are recommended for applications where the pumped liquid may damage the standard O-ring material.
Seal with flush, quench seal	Recommended for applications involving crystallizing, hardening or sticky liquids.
Cool-Top® shaft seal system	Recommended for applications involving extremely high temperatures. No conventional mechanical shaft seal can withstand liquid temperatures of up to 356 °F for any length of time. For that type of application, Grundfos' unique air-cooled shaft seal system is recommended. In order to ensure a low liquid temperature around the standard shaft seal, the pump is fitted with a special air-cooled shaft seal chamber. No separate cooling is required.
Double shaft seal with pressure chamber	Recommended for applications involving poisonous or explosive liquids. Protects the surrounding environment and the people working in the vicinity of the pump. Consists of two seals mounted in a "back-to-back" arrangement inside a separate pressure seal chamber. As the pressure in the chamber is higher than the pump pressure, leakage is prevented. A dosing pump or a special pressure-intensifier generates the seal chamber pressure.
CRN MAGdrive	Magnetically driven pumps for industrial applications. Key applications are industrial processes involving the handling of aggressive, environmental, dangerous or volatile liquids, e.g. organic compounds, solvents, etc.

Pumps

Variant	Description
Horizontally mounted pump	For safety or height reasons, certain applications, for instance on ships, require the pump to be mounted in the horizontal position. For easy installation the pump is equipped with brackets that support motor and pump.
Low-temperature pump to -40 °F	Exposed to temperatures down to -40 °F, coolant pumps may require neck-rings with a different diameter in order to prevent impeller drag.
High-speed pump up to 681 psi	For high-pressure applications, a unique pump capable of generating up to 681 psi pressure is available. The pump is equipped with a high-speed motor, type MLE. The direction of rotation is the opposite of that of standard pumps, and the chamber stack is turned upside-down, as a result of which the pumped liquid flows in the opposite direction.
High-pressure pump up to 696 psi	For high-pressure applications, a unique double pump system capable of generating up to 696 psi pressure is available.
Low-NPSH pump (improved suction)	Recommended for boiler-feed applications where cavitation may occur due to poor inlet conditions.
Belt-driven pumps	Belt-driven pumps designed to operate in places with limited space or where no electrical power is available.
Pumps for pharmaceutical and biotechnological applications	CRN pumps designed for applications requiring the sterilization and CIP capability of pipes, valves and pumps. (CIP = Cleaning-In-Place).

15. Quotation text

CR, CRI, CRN

Vertical, non-self-priming, multistage, in-line, centrifugal pump for installation in pipe systems and mounting on a foundation.

The pump has the following characteristics:

- Impellers and intermediate chambers are made of AISI _____ Stainless steel
- Pump head and base are made of _____
- Power transmission is via cast iron split coupling.
- Pipework connections is via _____
- The motor is a _____ -phase AC motor

Technical

Rated flow: _____ gpm
 Rated head: _____ Feet
 Minimum liquid temperature: _____ °F
 Maximum liquid temperature: _____ °F
 Type of shaft seal: _____

Materials

Material, pump housing: _____
 Material, shaft: AISI _____ Stainless Steel
 Material, impeller: AISI _____ Stainless Steel
 Material, sleeve: AISI _____ Stainless Steel
 Material, seal metal: AISI _____ Stainless Steel
 – seal face: _____
 – seal face: _____
 – seal elastomer: _____

Installation

Maximum ambient temperature: _____ °F
 Max. pressure at stated temp.: _____ PSI / °F
 Standard, pipe connection: _____
 Size, pipe connection: _____
 Rated pressure, pipe connection: _____ PSI
 Frame size for motor: _____ NEMA

Electrical data

Motor type: _____
 Rated power (P2): _____ Hp
 Frequency: _____ Hz
 Rated voltage: _____ V
 Rated current: _____ A
 Service factor: _____
 Starting current: _____ A
 Rated speed: _____ RPM
 Full load motor efficiency: _____ %
 Insulation class: _____

Additional

Gross weight: _____ Lbs.
 Shipping volume: _____
 Model: _____

16. Grundfos Product Center

Online search and sizing tool to help you make the right choice.

<http://product-selection.grundfos.com>



"SIZING" enables you to size a pump based on entered data and selection choices.

"REPLACEMENT" enables you to find a replacement product. Search results will include information on

- the lowest purchase price
- the lowest energy consumption
- the lowest total life cycle cost.

The screenshot shows the Grundfos Product Center website. At the top, there's a navigation bar with 'HOME', 'FIND PRODUCT', 'COMPARE', 'YOUR PROJECTS', 'SAVED ITEMS', and 'HELP'. Below this is a search bar with a 'SEARCH' button. The main content area features four large buttons: 'SIZING' (with a subtext 'Enter pump sizing'), 'CATALOG' (with a subtext 'Product and services'), 'REPLACEMENT' (with a subtext 'Replace an old pump with a new'), and 'LIQUIDS' (with a subtext 'Find liquid pump'). Below these is a 'QUICK SIZING' section with two columns of input fields. The first column is for 'Enter duty point' with fields for 'Flow (Q)*' and 'Head (H)*', each with a unit dropdown (US gpm and ft). The second column is for 'Select what to size by:' with radio buttons for 'Size by application', 'Size by pump design', and 'Size by pump family'. A 'START SIZING' button is located to the right of these options. At the bottom of the 'QUICK SIZING' section, there are 'ADVANCED SIZING' options: 'Advanced sizing by application' and 'Guided selection', both with gear icons.

"CATALOG" gives you access to the Grundfos product catalog.

"LIQUIDS" enables you to find pumps designed for aggressive, flammable or other special liquids.

All the information you need in one place

Performance curves, technical specifications, pictures, dimensional drawings, motor curves, wiring diagrams, spare parts, service kits, 3D drawings, documents, system parts. The Product Center displays any recent and saved items - including complete projects - right on the main page.

Downloads

On the product pages, you can download Installation and Operating Instructions, Data Booklets, Service Instructions, etc. in PDF format.

Grundfos GO

Mobile solution for professionals on the GO!

Grundfos GO is the mobile tool box for professional users on the go. It is the most comprehensive platform for mobile pump control and pump selection including sizing, replacement and documentation. It offers intuitive, handheld assistance and access to Grundfos online tools, and it saves valuable time for reporting and data collection.

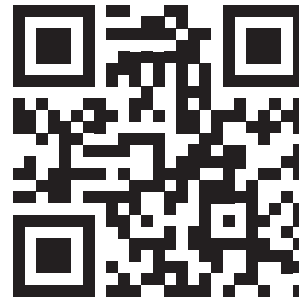
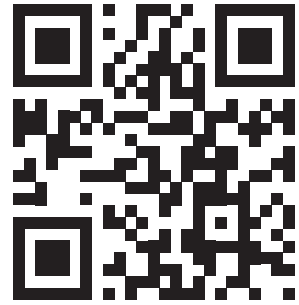

be think innovate

98446676 0618

ECM: 1235333

Grundfos Kansas City

17100 West 118th Terrace
Olathe, Kansas 66061
Phone: 913-227-3400
Fax: 913-227-3500
www.grundfos.us

Grundfos Canada

2941 Brighton Road
Oakville, Ontario L6H 6C9 Canada
Phone: +1-905-829-9533
Fax: +1-905-829-9512
www.grundfos.ca

Grundfos México

Boulevard TLC No. 15
Parque Industrial Stiva Aeropuerto
C.P. 66600 Apodaca, N.L. Mexico
Phone: 011-52-81-8144 4000
Fax: 011-52-81-8144 4010
www.grundfos.mx

© Copyright Grundfos Holding A/S

The name Grundfos, the Grundfos logo, and be think innovate are registered trademarks owned by Grundfos Holding A/S or Grundfos A/S, Denmark. All rights reserved worldwide.

GRUNDFOS 