

The Unilift CC are a range of multi-purpose submersible drainage pumps. Unilift CC will handle clean water, groundwater and grey wastewater with particles up to 10 mm. It can be completely or partly submerged in the liquid. The Unilift CC is a multi-purpose pump: it is excellent for both low-suction and standard drainage jobs.

The Unilift CC range is comprised of three different models: the CC 5, CC 7, and CC 9, all capable of handling particle sizes up to 10 mm. The range covers a wide application area: flows from 6 m³/h to 14 m³/h and heads from 5 to 9 m. Every model is available with or without a float switch for automatic or manual operation.

The Unilift CC pump sleeve is made from composite material that combines lightness with strength. Naturally, the composite is corrosion-free and withstands the trials of everyday handling extremely well.

FEATURES AND BENEFITS

- Suitable for both regular and low-suction drainage jobs.
- Self-venting valve prevents air getting trapped in pump.
- Can be used for continuous operation as long as water level is at least 25mm.
- Sealed cable inlet prevents moisture from entering the pump motor.
- Includes built-in thermal overload protection.



Pump type	Max Flow (m ³ /h)	Max Head (m)
Unilift CC 5	6	5
Unilift CC 7	10	7
Unilift CC 9	14	9

PERFORMANCE CURVE

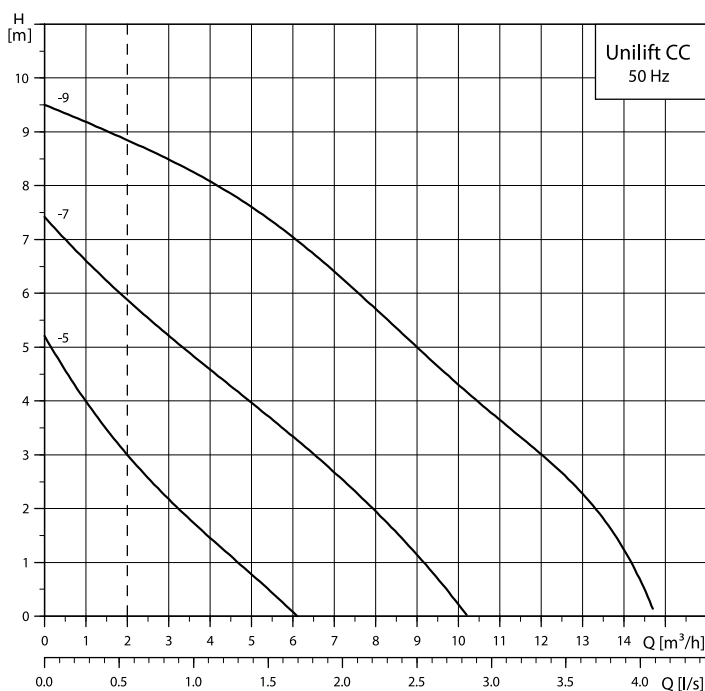

DIMENSIONS

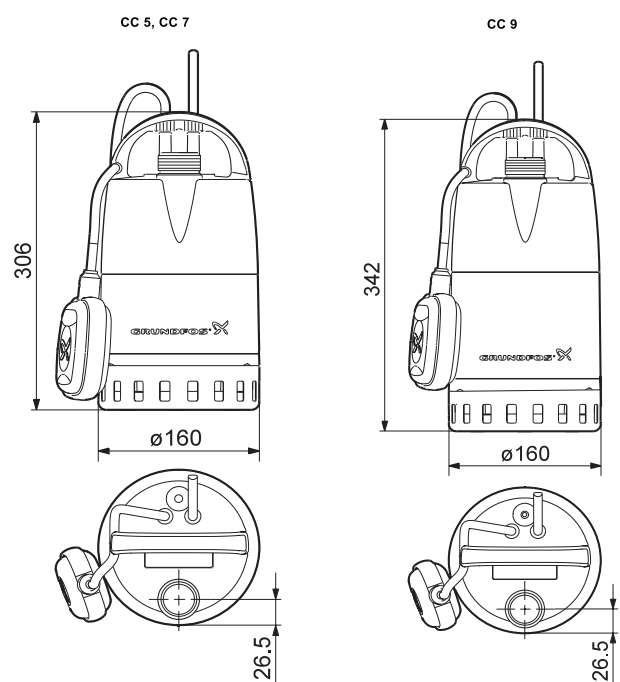

INSTALLATION

- The pump must not be installed hanging from the electric cable or the discharge pipe.
- Do not lift or lower the pump by means of the electric cable.

Pump with float switch

If the pump is installed in a well, the minimum dimensions of the well should be as shown in Fig. 1 and the table to ensure free movability of the float switch.

Fig. 1

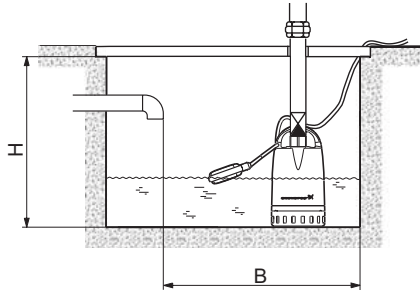

Minimum installation dimensions

Pump type	Height (H) (mm)	Width (B) (mm)
Unilift CC 5	520	400
Unilift CC 7	520	400
Unilift CC 9	570	500

Pump without float switch

The space required corresponds to the physical dimensions of the pump (see overleaf).

Pump location

The pump can be used in vertical position and in tilted or horizontal position with the discharge port as the highest point of the pump. The suction strainer must be covered by the pumped liquid.

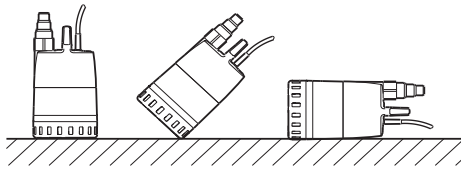

Position the pump so that the suction strainer is free of silt, mud or similar materials. This can be ensured by placing the pump on bricks, an iron plate etc.

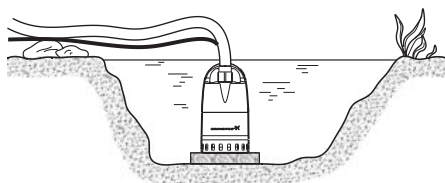

OPERATING CONDITIONS

Liquid Temperature

0°C to +40°C

At intervals of at least 30 minutes, the pump is allowed to run at maximum +70°C for periods not exceeding 2 minutes.

Storage Temperature

-10°C to +40°C

Installation depth

Maximum 10 metres below water surface.

TECHNICAL DATA

Pump performance

Pump type	Unilift CC 5	Unilift CC 7	Unilift CC 9
Max. head (m)	5	7	9
Max. flow rate (m ³ /h)	6	10	14
Insulation class	B	F	B
Thermal protection cuts out at (°C)	140	160	140

Maximum permissible dry-running time

1 minute

Maximum particle size

Ø 10mm

Enclosure class

IP 68

ELECTRICAL DATA

Pump type	Unilift CC 5	Unilift CC 7	Unilift CC 9
Voltage (V)	220-240	220-240	220-240
Current I _{1/1} (A)	1.0	1.8	3.5
Power, P ₁ (W)	250	380	780
Power factor, cos φ _{1/1}	0.973	0.953	0.93
Cable type	H05RN-F 3GO.75	H07RN-F 3G1	H07RN-F 3G1

Sound pressure level

< 55dB(A).